

# FOM-E3, FOM-T3

E3/T3 Fiber Optic Modems

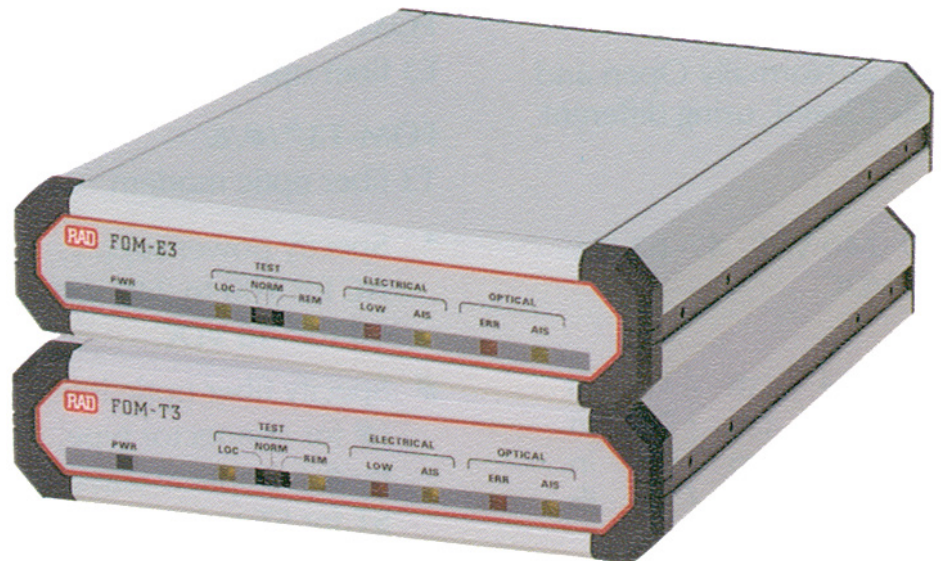

Convert E3/T3 electrical signals into optical signals, extending the E3/T3 service range up to 110 km (68.3 miles)

- High-speed fiber optic modems
- Transparent to E3/T3 signals
- Available with laser diode option for extended ranges
- Operate over single mode or multimode fibers
- Conform to all relevant ITU series standards, including V.54 diagnostics support



## FOM-E3, FOM-T3 E3/T3 Fiber Optic Modems

The FOM-E3 and FOM-T3 fiber optic modems convert E3/T3 electrical signals into optical signals for transmission over fiber optic cable to extend the E3/T3 service range to up to 110 km (68.3 miles).

FOM-E3 and FOM-T3 support various optical interfaces:

- 850 nm VCSEL for multimode fiber
- 1310 nm laser for single-mode or multimode fiber
- 1310 nm and 1550 nm long-haul lasers for extended range over single-mode fiber
- WDM laser for transmission over a single fiber.

The modems are compatible with RAD's DXC, Optimux-34, Optimux-45, FOM-E3/ETH and FOM-T3/ETH devices.

FOM-E3 and FOM-T3 support activation of local and remote loopbacks in compliance with ITU V.54.

Front panel LEDs indicate system faults in the electrical and fiber optic circuits.

An alarm relay port transmits the following alarm conditions:

- Minor alarm – AIS received at the electrical or fiber optic interface
- Major alarm – low level of E3/T3 electrical input or high bit error rate at the fiber optic interface.

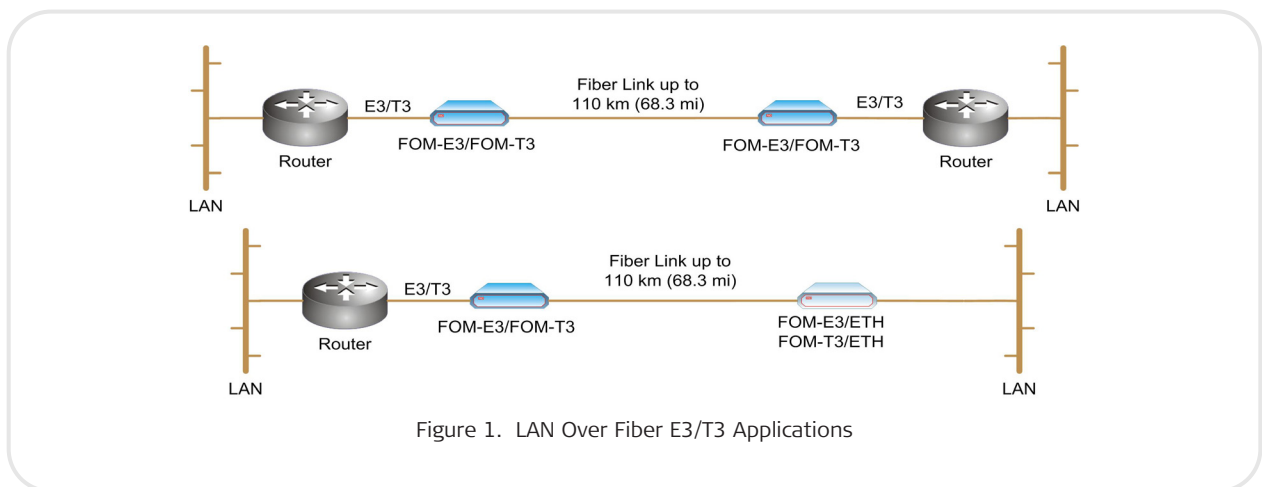

Figure 1. LAN Over Fiber E3/T3 Applications

## Specifications

### E3/T3 ELECTRICAL INTERFACE

#### Transmission Rate

E3: 34.368 Mbps  
T3: 44.736 Mbps

#### Impedance

75Ω, unbalanced

#### Zero Suppression

E3: HDB3  
T3: B3ZS

#### Connectors

Two BNC

### FIBER OPTIC INTERFACE

#### Interface Characteristics

See *Table 1*

#### Connectors

ST, SC, SC-APC or FC

### GENERAL

#### Diagnostics

Comply with ITU V.54; local and remote loopbacks activated via slide switch

#### Alarm Relay Port

Dry contact via 9-pin, D-type, female connector. Operates as normally open and normally closed, using different pins

#### Indicators

PWR (green): Power status  
TEST LOC (yellow): Local loopback is active  
TEST REM (yellow): Remote loopback is active  
OPTICAL AIS (yellow): FO AIS status  
OPTICAL ERR (red): FO bit error status  
ELECTRICAL LOW (red): Electrical input status  
ELECTRICAL AIS (yellow): Electrical AIS status

### Physical

Height: 4.4 cm (1.7 in)  
Width: 19.4 cm (7.6 in)  
Depth: 24.3 cm (9.6 in)  
Weight: 1.4 kg (3.0 lb)

### Power

AC: 100–240 VAC, 47–63 Hz  
DC: –48 VDC, 6.5W

### Environment

Temperature: 0°–45°C (32°–113°F)  
Humidity: Up to 90%, non-condensing

Table 1. Fiber Optic Interface Characteristics

Wavelength	Fiber Type	Transmitter Type	Power	Receiver Sensitivity*	Typical Max. Range**	
[nm]	[μm]		[dBm]	[dBm]	[km]	[miles]
850	62.5/125 multimode	VCSEL	-15	-31	4.5	2.8
1310	62.5/125 multimode	Laser	-9	-31	5.5	3.4
1310	9/125 single mode	Laser	-12	-31	38	23.6
1310	9/125 single mode	Laser (long haul)	-2	-34	70	43.4
1550	9/125 single mode	Laser	-12	-31	68	42.2
1550	9/125 single mode	Laser (long haul)	-1	-34	110	68.3
1310/1550	9/125 single mode	Laser (WDM), SF1, SF2	-12	-30	40	24.9
1310	9/125 single mode	Laser (WDM), SF3	-12	-27	24	14.9

\* Receiver sensitivity is calculated for BER = 10E<sup>-9</sup>.  
\*\* Range is calculated according to the following typical attenuation rates: 3.5 dB/km for 850 nm multimode, 0.5 dB/km for 1300 nm single mode, 0.25 dB/km for 1550 nm single mode. The max. range assumes a margin of 3 dB.

# FOM-E3, FOM-T3

## E3/T3 Fiber Optic Modems

### Ordering

FOM-E3/~ /ab

FOM-T3/~ /ab

#### Legend

~ Power supply type:  
**AC** 100 to 240 VAC  
**48** -20 to -72 VDC

**a** Connector type:  
**ST** ST connector  
**SC** SC connector  
**FC** FC connector  
**SC-APC** SC-APC connector

*Note:* SC-APC connector can only be ordered with SF3 transmitter

**b** Optical wavelength and transmitter:  
**85** 850 nm, multimode, VCSEL  
**13MM** 1310 nm, multimode, laser  
**13L** 1310 nm, single mode, laser  
**15L** 1550 nm, single mode, laser  
**13LH** 1310 nm, single mode, long-haul laser  
**15LH** 1550 nm, single mode, long-haul laser  
**SF1** Tx 1310 nm, Rx 1550 nm, WDM laser  
**SF2** Tx 1550 nm, Rx 1310 nm, WDM laser  
**SF3** Tx/Rx 1310 nm, WDM laser

*Note:* SF1 and SF2 transmitters can only be ordered with SC connector and SF3 transmitter can only be ordered with SC-APC connector

### SUPPLIED ACCESSORIES

AC power cord  
 DC connection kit (when DC power supply is ordered)

### OPTIONAL ACCESSORIES

**RM-9**  
 Hardware kit for mounting one or two FOM-E3 or FOM-T3 units in a 19-inch rack

Table 2. Fiber Optic Modem Comparison Chart

Feature	FOM-E1/T1	FOMi-E1/T1	FOM-20	FOM-40	FOMi-40	FOM-E3 FOM-T3	FOMi-E3 FOMi-T3	FOM-E3 ETH FOM-T3 ETH
Data rates [kbps]	E1/T1	E1/T1	19.2-256	56-2048	56-2048	E3 T3	E3 T3	E3 T3
DTE interfaces	G.703	G.703	Serial, Ethernet	Serial, Ethernet	Serial, Ethernet, E1/T1	G.703	G.703, HSSI	10/100BaseT VLAN bridge
SNMP management	-	✓	-	-	✓	-	✓	-
Card version for rack	ASM-MN-214	LRS-24	ASM-MN-214	ASM-MN-214	LRS-24	-	LRS-24	-

**International Headquarters**  
 24 Raoul Wallenberg Street  
 Tel Aviv 69719, Israel  
 Tel. 972-3-6458181  
 Fax 972-3-6498250, 6474436  
 E-mail market@rad.com



12 avenue des prés  
 78059 St Quentin en Yvelines  
 Tel: 33 (0)1 77 55 03 00  
 Fax: 33 (0)1 30 44 11 95  
 E-mail: sales@cbnetworks.fr



**data communications**  
 The Access Company