

LRS-16

Managed SHDSL Modem Concentrator



- Transparent modem concentrator with SNMP management
- E1 services over 16 SHDSL 2-wire lines
- Multiple data rates between 64 kbps and 2048 kbps
- Convenient and low-cost maintenance on PC or UNIX (HPOV) platforms using RADview SNMP management
- ASCII terminal or Telnet management

Managed low-cost
SHDSL modem rack
with 16 E1 channels
over SHDSL 2W lines

LRS-16 is a high-density SNMP managed modem concentrator. The chassis accommodates 16 fixed SHDSL modems, providing E1 services over 2-wire lines.

LRS-16 employs standard SHDSL TC-PAM16 technology to extend the transmission range, thus enabling carriers to reach more customers at lower costs.

The device uses an Embedded Operation Channel (EOC) for controlling and monitoring the remote unit. The management channel uses SHDSL overhead bits in compliance with ITU-T G.991.2 requirements, and operates without interfering with the data transmission.

The SHDSL port can be ordered with either 8 x RJ-45 connectors or 2 x DB-26 connectors convertible to 8 x RJ-45 via adaptor cable. In the latter case, the Ethernet ports are available with either 2 UTP or 1 UTP + 1 fiber-optic (SFP) connectors. The device with 8 x RJ-45 connectors is always supplied with 2 UTP connectors on the Ethernet ports.



LRS-16

Managed SHDSL Modem Concentrator

LRS-16 is supplied in a 1U-high 19-inch enclosure.

TIMING

Each of the 16 ports inside the LRS-16 CO device can be separately clocked and locked on one of the following timing clock sources:

- Internal, derived from LRS-16's internal oscillator
- External, supplied by the E1 port interface.
- System, supplied by the station clock input.

LRS-16 has a station clock connection enabling clock distribution to all ports, so that all ports can be synchronized to the same station clock.

POWER SUPPLIES

LRS-16 operates with single or dual power supplies. A power supply can be hot-swapped (replaced) during operation, without affecting system performance.

MANAGEMENT

LRS-16 is managed by a UNIX- or PC-based SNMP management system. The user-friendly software is GUI-based and runs on PC/Windows or HP-OpenView platforms. The SNMP management session can run over a 10/100BaseT Ethernet port.

Network management allows centralized control of all LRS-16 hubs, modem ports and remote modems in the network, including interface configuration, connection setup, alarms and monitoring. A single management station can control up to 64,000 LRS-16 hubs.

LRS-16 can also be managed from an ASCII terminal that performs all SNMP functions without a GUI.

Telnet allows terminal connection over any IP network.

The LRS-16 front panel features a two-digit alphanumeric display. When there are multiple hubs in the network, this display shows the number of the hub that can be configured by the user during normal operation.

DIAGNOSTICS

LRS-16 features comprehensive diagnostic capabilities activated from either the ASCII terminal or an SNMP management tool. They include the following test options:

- Local analog and remote digital loopbacks
- SHDSL statistics collection for line performance monitoring
- E1 performance statistics per ITU-T G.706 requirements.

Performance information for the last 24 hours is available in graph and table format and can be saved in a file for accounting purposes.

Table 1. Typical Ranges

Data Rate [kbps]	Range, 2-wire	
	[km]	[mi]
192	6.2	3.8
384	5.8	3.6
768	5.5	3.5
1024	5.4	3.4
1536	5.0	3.1
2048	4.6	2.8

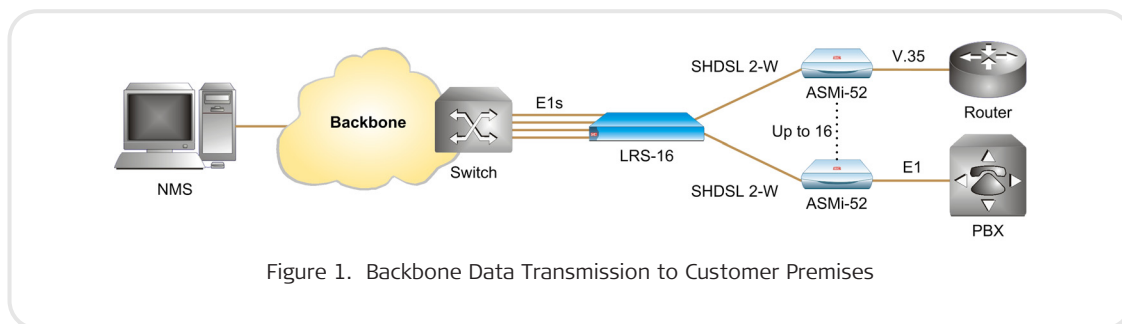

Figure 1. Backbone Data Transmission to Customer Premises

Specifications

SHDSL LINE INTERFACE

Standard

ITU-T G.991.2

Number of Ports

16

Type

2-wires unconditioned dedicated line (twisted pair)

Line Coding

TC-PAM 16

Line Rate

192 to 2048 kbps in steps of 64 kbps

Range

See *Table 1* (26 AWG, 0.4 mm PE, noise free)

Impedance

135Ω

Connectors

2 x DB-26 convertible to 8 RJ-45 connectors via adaptor cable

8 x RJ-45 for 16 pairs (one RJ-45 per 2 x 2-wires)

E1 INTERFACE

Number of Ports

16

Standards

ITU-T G.703, ITU-T G.704

Data Rate

64 kbps up to 2048 Kbps

Coding

HDB3

Line Impedance

120Ω, balanced

75Ω, unbalanced (via adapter cable)

MANAGEMENT PORTS

Control Port

Type: V.24/RS-232

Rates: 9.6, 19.2, 38.4, 57.6, 115.2 kbps

Characters: Async, 8 bits, 1 stop bit, no parity

Terminals supported: VT-52, VT-100, VT-920

Connector: D-type, 9-pin female

ETH-MNG PORTS

Ports

2 UTP

1 UTP + 1 fiber-optic (SFP)*

*This option is selectable only when SHDSL port connectors are DB-26, see *Table 3*.

Data Rate

10/100 Mbps (Fast Ethernet)

Autonegotiation

Connectors

2 x RJ-45, shielded

1 x RJ-45 + 1 x SFP transceivers (see *Ordering*)

SFP Characteristics

For full details, see the *SFP Transceivers data sheet* at www.rad.com

TIMING

Sources

Internal, derived from internal oscillator

External, supplied by the E1 port interface

System, supplied by the station clock input

Station Clock

Rate: 2048 kHz

Connector: 15 pin, D-type female

Coding: HDB3/square

DIAGNOSTICS

Statistics & Performance Monitoring

E1 with CRC-4 per ITU-T G.706

E1 without CRC-4

SHDSL performance

Diagnostics

Loopbacks on local and remote E1 ports

Loopbacks and BERT on the SHDSL line

INDICATORS

PWR (green) – Power supply on

Rack indicator – 2-character display for the last two digits of the hub number

TST (yellow) – On: a test is active

ALM (red) – On: an alarm is detected in the alarm buffer

SHDSL Ports

Sync (red/green):

Green – the DSL line is synchronized

Red Flashing – the DSL line is in synchronization process

Red – the DSL line is not synchronized and not in sync process

E1 Ports

SYNC (red) – On: Local E1 sync loss (for framed E1), signal loss (for unframed E1)

AIS (red) – On: All 1's received on E1 port

Ethernet Ports

LINK (green) – LAN link integrity

ACT (yellow) – LAN data activity

Power Supply

100–240 VAC, 50/60 Hz

48/60 VDC nominal (40 to 72 VDC)

Power Consumption

15W

Physical

Height: 43.7 mm (1.7 in)

Width: 440 mm (17.3 in)

Depth: 240 mm (19.4 in)

Weight: 3.9 kg (138.3 oz)

Environment

Temperature: 0° to 50°C (32° to 122°F)

Humidity: Up to 90%, non-condensing

Table 2. LRS Family Comparison Chart

	LRS-16	LRS-24	LRS-102
Max. E1 ports	16	44	96
Max. Ethernet ports	2 (mng)	32	24
Ethernet performance	N/A	VLAN transparent	VLAN aware, VLAN stacking/stripping

LRS-16

Managed SHDSL Modem Concentrator

Ordering

LRS-16/\$/16E1/2W/*

Legend

\$ Power supply:

- AC** 100 to 240 VAC
- ACR** dual 100 to 240 VAC
- 48** -48 VDC
- 48R** dual -48 VDC
- AC48** one AC, one DC

* Ethernet management port interface and connectors (Default=2UTP with RJ-45 SHDSL port connectors, see Table 3):

- 2UTP** 2 UTP
- UTP/SFPa** 1 UTP + 1 SFP socket including SFP transceivers (see below for a)

Note: This option is selectable only when SHDSL port connectors are DB-26. To order RJ-45 connectors on the SHDSL port, do not specify this option.

a SFP transceivers for Ethernet 100BaseFx Interface

- 1** Fast Ethernet/STM-1, 1310 nm, multimode, LED, 2 km (1.2 mi)
- 1D** Fast Ethernet/STM-1, DDM, internal calibration, 1310 nm, multimode, LED, 2 km (1.2 mi)
- 2** Fast Ethernet/STM-1, 1310 nm, single mode, laser, 15 km (9.3 mi)
- 2D** Fast Ethernet/STM-1, DDM, internal calibration, 1310 nm, single mode, laser, 15 km (9.3 mi)
- 3** Fast Ethernet/STM-1, 1310 nm, single mode, laser, 40 km (24.8 mi)

- 3D** Fast Ethernet/STM-1, DDM, internal calibration, 1310 nm, single mode, laser, 40 km (24.8 mi)
- 10A** Fast Ethernet/STM-1, Tx - 1310 nm, Rx - 1550 nm, single mode (single fiber), laser (WDM), 20 km (12.4 mi)
- 10B** Fast Ethernet/STM-1, Tx - 1550 nm, Rx - 1310 nm, single mode (single fiber), laser (WDM), 20 km (12.4 mi)
- 18A** STM-1/OC-3, Tx - 1310 nm, Rx - 1550 nm, 9/25 single mode (single fiber), laser (WDM), 40 km (24.8 mi)
- 18B** STM-1/OC-3, Tx - 1550 nm, Rx - 1310 nm, 9/25 single mode (single fiber), laser (WDM), 40 km (24.8 mi)
- 19A** STM-1/OC-3, Tx - 1490 nm, Rx - 1570 nm, 9/25 single mode (single fiber), laser (WDM), 80 km (49.7 mi)
- 19B** STM-1/OC-3, Tx - 1570 nm, Rx - 1490 nm, 9/25 single mode (single fiber), laser (WDM), 80 km (49.7 mi)

Notes.

- For the complete list of SFPs, refer to the SFP Transceivers data sheet.

- It is strongly recommended to order LRS-16 with original RAD SFPs installed. This will ensure that prior to shipping, RAD has performed comprehensive functional quality tests on the entire assembled unit, including the SFP devices. RAD cannot guarantee full compliance to product specifications for LRS-16 units using non-RAD SFPs.

SUPPLIED ACCESSORIES

- AC power cord (when AC power supply is ordered)
- DC adapter plug (when DC power supply is ordered)

RM-34

Hardware for mounting one unit in a 19-inch rack

OPTIONAL ACCESSORIES

CBL-DB9F-DB9M-STR

Control port cable

CBL-RJ45/2BNC/E1

RJ-45 to BNC adaptor cable

CBL-DB26-8SHDSL

Cable for splitting a single 26-pin connector into 8 x RJ-45 connectors

Note: This cable is required for the device operation. It can either be ordered from RAD or manufactured by the customer according to pinouts provided in the manual.

Table 3. SHDSL and Management Port Combinations

Ordering Option	SHDSL Ports	Management Ports
LRS-16/\$/16E1/2W	8 x RJ-45	2 x UTP
LRS-16/\$/16E1/2W/2UTP	2 x DB-26	2 x UTP
LRS-16/\$/16E1/2W/UTP/SFPa	2 x DB-26	1 UTP + 1 SFPa

International Headquarters
 24 Raoul Wallenberg Street
 Tel Aviv 69719, Israel
 Tel. 972-3-6458181
 Fax 972-3-6498250, 6474436
 E-mail market@rad.com



12 avenue des prés
 78059 St Quentin en Yvelines
 Tel: 33 (0)1 77 55 03 00
 Fax: 33 (0)1 30 44 11 95
 E-mail: sales@cbnetworks.fr



data communications
 The Access Company