

Optimux-108, Optimux-106

Fiber Multiplexer for 4 E1/T1 and Ethernet or Serial Data



Fiber Multiplexers,
Transmit Any Traffic
over Fiber



- Four E1 or T1 channels and Fast Ethernet link multiplexed over a fiber optic link
- Various fiber interfaces: multimode, single-mode (up to 120 km), and/or single-mode over single fiber, using SFP optical modules
- Automatic link backup with optional hot-swappable second main link
- Card versions for connecting up to 24 remote units to one LRS-102 rack (12 cards)
- Power redundancy with optional second wide-range power supply
- Management via ASCII terminal, dedicated Ethernet port, SNMP management station, or a Web-based remote access terminal

The Optimux-108 and Optimux-106 multiplexers combine four E1 or T1 channels and an optional Ethernet link over a fiber optic uplink.

A pair of Optimux units provides a simple and low-cost solution for connectivity over distances of up to 120 km (74.5 miles).

For transmission reliability, an optional modular second link provides automatic backup upon link failure. An optional second power supply provides power redundancy for failsafe operation.

Each of the four signals of the tributary interface is transmitted independently, so that each channel can be set to a different clock source.



Optimux-108, Optimux-106

Fiber Multiplexer for 4 E1/T1 and Ethernet or Serial Data

STANDALONE UNITS

Uplink Interfaces

Optimux-108/106 supports a variety of built-in optical uplink interfaces including:

- 850 nm VCSEL (Vertical Cavity Surface Emitting Laser) for multimode fiber
- 1310 nm LED for multimode fiber
- 1310/1550 nm laser diode or long haul laser diode for extended range over single-mode fiber
- Single fiber (SF1, SF2 options) using a 1310 nm and 1550 nm laser diode transmitter with WDM technology, which enables the laser to transmit the signal at a different wavelength than the receive signal
- Single fiber (SF3 option) using SC/APC (Angle-Polished Connector) technology, with a 1310 nm laser diode for single wavelength operation.

The basic models include a fiber optic uplink and four tributary E1/T1 links. The standalone units are supplied with balanced E1 and T1 interfaces. Optimux-108 can be ordered with unbalanced E1 interfaces.

Optimux-108/106 can be ordered with an additional Ethernet user port (VLAN transparent), and with redundant uplink. Optimux-108 can also be ordered with a V.35 interface in place of the Ethernet user port.

Diagnostics

Optimux features comprehensive test and diagnostics capabilities that include local and remote loopbacks on the uplink interface and on each E1/T1 tributary link. A local loopback is also supported on the optional V.35 user port.

To facilitate system diagnostics, Optimux-108/106 features LED status indicators, AIS alarm generation and recognition, and dry contact closure upon link failure.

Management

Optimux-108/106 can be configured and monitored locally using an ASCII terminal connected to the control port or remotely via the Ethernet management port using:

- RADview-EMS running in a Windows or Unix environment
- Web-based remote access terminal
- Telnet.

Power

The power supply is a wide-range AC/DC power supply that can be connected to either an AC power source (100 to 240 VAC), or a DC power source (-40 to -125 VDC). An optional second power supply provides redundancy. As an option, the devices can also be ordered with a non-redundant 24 VDC power supply (20 to 36 VDC).

Physical

Optimux-108/106 is a compact standalone unit, available in plastic or metal enclosures. The metal enclosures are available in extended temperature versions. The optional rack mount adapter kits enable installation of one or two (side-by-side) units in a 19-inch rack.

CARD MODULES

The OP-108C and OP-106C multiplexers are cards designed for operation in the LRS-102 chassis. They combine up to eight E1 or T1 channels and two optional Ethernet links over two fiber optic links from two remote units (up to four E1/T1 and 100 Mbps Ethernet traffic from each remote unit).

The LRS-102 chassis accommodates up to 12 cards (24 links). An Optimux link provides a simple and low-cost solution for connectivity over distances of up to 120 km (74.5 miles).

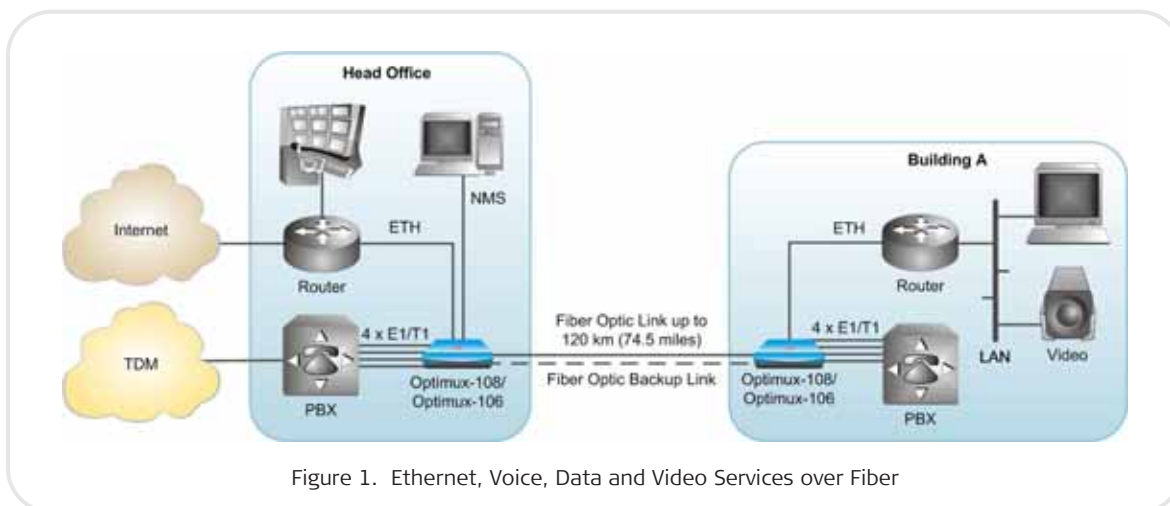

Figure 1. Ethernet, Voice, Data and Video Services over Fiber

Uplink Interfaces

Pluggable SFP units provide the uplink interfaces. A wide variety of optical interfaces are available for ordering as single, dual, or quad modules (see *Table 2* and *Ordering Options*).

It is strongly recommended to order this device with **original RAD SFPs installed**.

This will ensure that prior to shipping, RAD has performed comprehensive functional quality tests on the entire assembled unit, including the SFP devices. RAD cannot guarantee full compliance to product specifications for units using non-RAD SFPs.

Redundancy

For transmission reliability, an optional modular second link provides automatic backup upon link failure. LRS-102 provides power redundancy for nonstop operation.

Diagnostics

OP-108C and OP-106C feature comprehensive test and diagnostics capabilities that include local and remote loopbacks on the uplink interface and on each E1/T1 tributary link.

To facilitate system diagnostics, the card versions feature LED status indicators and AIS alarm generation and recognition.

Management

Setup, control, and diagnostics are performed by the LRS-102 management rack. The same management options are available as for the standalone versions.

Physical

Each card fits in a single slot of the LRS-102 chassis.

Note: For OP-108C/OP-106C cards operating in the Megaplex-4100 enclosure, refer to a separate OP-108C/OP-106C data sheet included into the Megaplex-4100 folder.

Power

The power for cards is provided by the LRS-102 power supply.

Specifications

FIBER OPTIC INTERFACES

Optimux-108/Optimux-106: See *Table 1*
 OP-108C/OP-106C: See *Table 2*

TRIBUTARY INTERFACES

Number of E1/T1 Channels

Standalone: 4
 Card: 2 x 4 E1/T1 channels

Data Rate

E1: 2048 kbps
 T1: 1544 kbps

Line Code

E1: HDB3
 T1: B8ZS

Impedance

120Ω, E1 balanced
 100Ω, T1 balanced
 75Ω, E1 unbalanced

Connectors

Optimux-108
 E1 balanced: RJ-45
 E1 unbalanced: a pair of BNC

Optimux-106
 RJ-45

OP-108C

E1 balanced: DB-44 connector on the front module panel convertible to 80 balanced interfaces via adaptor cables (see *Ordering Options*)

E1 unbalanced:

- DB-44 connector on the front module panel convertible to 80 unbalanced interfaces via adaptor cables (see *Ordering Options*)
- A pair of BNC connectors for each E1 port on a special LRS-102 rack version

OP-106C

DB-44 connector on the front module panel convertible to 80 balanced T1 interfaces via adaptor cables (see *Ordering Options*)

MNG-ETH INTERFACE (STANDALONE ONLY)

Type

10/100BaseT

Connector

Shielded RJ-45

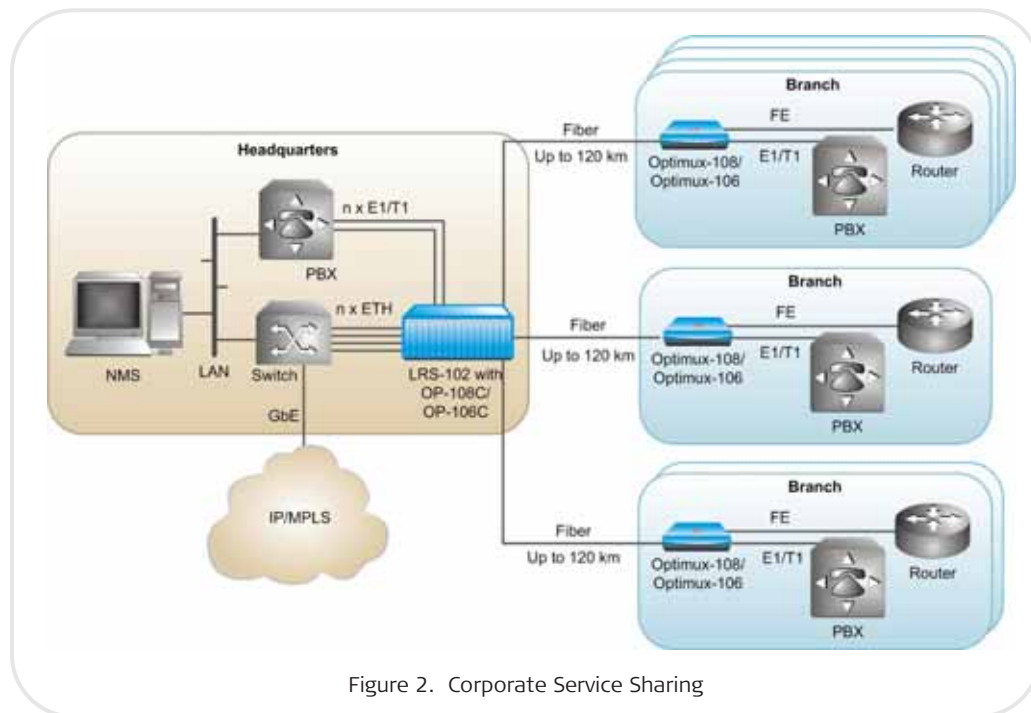

Figure 2. Corporate Service Sharing

Optimux-108, Optimux-106

Fiber Multiplexer for 4 E1/T1 and Ethernet or Serial Data

USER ETH INTERFACE

Type
10/100BaseT

Connector
Shielded RJ-45

Throughput
Optimux-108, OP-108C: 100 Mbps
Optimux-106, OP-106C: 75 Mbps

Maximum Frame Size
1536 bytes

V.35 USER INTERFACE (E1 STANDALONE ONLY)

Type
DCE

Connector
Smart Serial

Throughput
2 Mbps

CONTROL PORT (STANDALONE ONLY)

Type
RS-232 DCE asynchronous

Data Rate
9.6, 19.2, 38.4, 57.6, 115.2 kbps

Connector
Mini-USB 5

ALARM PORT (STANDALONE ONLY)

Type
Dry relay contacts for major and minor alarms

Connector
RJ-45

STANDALONE INDICATORS

Front Panel

PWR
On (green): both power supplies OK
On (red): power supply A fault
On (yellow): power supply B fault
Off: Both power supplies fault or no power

LOS/AIS – LINK A/B
On (red): Sync/Signal Loss on Link A/B
On (yellow): AIS detected (products without Ethernet port only)
Off: normal operation

LOS/AIS – CH1 to CH4
On (red): Signal Loss on channel
On (yellow): AIS received on channel
Off: normal operation

Table 1. Standalone Fiber Optic Interface Characteristics

Wavelength [nm]	Fiber Type [μm]	Transmitter Type	Typical Power Output [dBm]	Receiver Sensitivity w/o USER ETH port [dBm]	Receiver Sensitivity with USER ETH port [dBm]	Typical Max. Range w/o USER ETH port [km] [miles]	Typical Max. Range with USER ETH port [km] [miles]	Connector Type	Extended Temperature Version
850	62.5/125 multimode	Laser (VCSEL)	-6	-34	-32	6 3.7	2 1.2	ST, SC, FC/PC	No
1310	9/125 single mode	Laser	-12	-34	-28	47 29.2	20 12.4	ST, SC, FC/PC	Yes
1310	62.5/125 multimode	LED	-18	-32	-30	7 4.3	2 1.2	ST, SC	No
1550	9/125 single mode	Laser	-12	-34	-28	47 29.2	20 12.4	ST, SC, FC/PC	Yes
1310	9/125 single mode	Laser (long haul)	-2	-34	-34	72 44.7	40 24.8	ST, SC, FC/PC	Yes
1550	9/125 single mode	Laser (long haul)	-2	-34	-34	120 74.5	80 49.7	ST, SC, FC/PC	Yes
Tx: 1310 Rx 1550	9/125 single mode	Laser WDM (SF1)	-12	-34	-28	47 29.2	20 12.4	SC	No
Tx: 1550 Rx 1310	9/125 single mode	Laser WDM (SF2)	-12	-34	-28	47 29.2	20 12.4	SC	No
Tx/Rx: 1310	9/125 single mode	Laser (SF3)	-12	-27	-27	20 12.4	20 12.4	SC/APC only	No

Note: Typical ranges are calculated according to attenuation of 3.5 dB/km for 850 nm multimode fiber, 0.4 dB/km for 1310 nm single mode fiber, and 0.25 dB/km for 1550 nm single mode fiber.

Rear Panel

Sig Link A/B (on the fiber optic module)
 On (green): signal exists on Link A/B
 Off: no signal on Link A/B

LINK/ACT

On (yellow): link is up
 Off: link is down
 Blinking: frames are transmitted

100

On (green): 100 Mbps mode
 Off: 10 Mbps mode

CARD INDICATORS

Link

OP A/B LOS
 On (red): Sync/Signal Loss on OP A/B
 Off: Normal operation

OP A/B AIS

On (yellow): AIS detected (only for operating opposite Optimux-108/106 without Ethernet port)
 Off: Normal operation

(OP A/B LOS and AIS are On if the SFP is not inserted.)

Ethernet

OP A/B LINK/ACT
 On (yellow): link is up
 Off: link is down
 Blinking: frames are transmitted

OP A/B 100

On (green): 100 Mbps mode
 Off: 10 Mbps mode

GENERAL

Compliance

G.703, G.823 (E1), G.824 (T1), G.955, IEEE 802.3
 G.742 (Optimux-108 without Ethernet ports)

Diagnostics

Local and remote loopbacks on uplink and on each E1/T1 tributary link
 Local loopback on optional V.35 user port (Optimux-108 only)

Timing

Uplink: internal
 E1/T1 tributary: transferred transparently, independent for each channel
 V.35: internal, external, loopback (Optimux-108 only)

Power

Standalone:
 Wide range power supply
 • AC: 100 to 240 VAC
 • DC: -48 VDC (-40 to -125 VDC)
 24 VDC power supply
 • 24 VDC (20 to 36 VDC)
 Card: supplied by LRS-102

Power Consumption

Standalone:
 • Wide-range AC: 25 VA max
 • Wide-range DC (-48 VDC): 9W max
 • 24 VDC: 9W max
 Card: 9W max

Table 2. SFP Fiber Optic Interface Characteristics for OP-108C/106C Cards

Module Name	Wave-length [nm]	Fiber Type	Transmitter Type	Typical Output Power [dBm]	Receiver Sensitivity w/o USER ETH port [dBm]	Receiver Sensitivity with USER ETH port [dBm]	Typical Max Range w/o USER ETH port [km][miles]	Typical Max Range with USER ETH port [km] [miles]	Connector Type
SFP-1	1310	62.5/125 multimode	LED	-18	-31	-30	6.5 4.0	2 1.2	LC
SFP-2	1310	9/125 single mode	Laser	-12	-31	-28	38 23.6	20 12.4	LC
SFP-2H	1310	9/125 single mode	Laser	-12	-31	-28	38 23.6	20 12.4	LC
SFP-3	1310	9/125 single mode	Long haul laser	-2	-34	-34	70 43.4	40 24.8	LC
SFP-3H	1310	9/125 single mode	Long haul laser	-2	-34	-34	70 43.4	40 24.8	LC
SFP-4	1550	9/125 single mode	Long haul laser	-2	-34	-34	120 74.5	80 49.7	LC
SFP-10a	Tx - 1310, Rx - 1550	9/125 single mode (single fiber)	Laser WDM	-12	-30	-28	40 24.8	20 12.4	LC
SFP-10b	Tx - 1550, Rx - 1310	9/125 single mode (single fiber)	Laser WDM	-12	-30	-28	40 24.8	20 12.4	LC
SFP-18A	Tx - 1310, Rx - 1550	9/125 single mode (single fiber)	Laser WDM	-2	-30	-28	60 37.3	40 24.8	LC
SFP-18B	Tx - 1550, Rx - 1310	9/125 single mode (single fiber)	Laser WDM	-2	-30	-28	60 37.3	40 24.8	LC
SFP-24	850	62.5/125 multimode 50/125 multimode	VCSEL	-7	-31	-25	6.5 4.0	1 0.6 2 1.2	LC

Note: Typical ranges are calculated according to attenuation of 0.4 dB/km for 1310 nm single mode fiber and 0.25 dB/km for 1550 nm single mode fiber.

Optimux-108, Optimux-106

Fiber Multiplexer for 4 E1/T1 and Ethernet or Serial Data

Physical

Standalone plastic enclosure:

Height: 4.37 cm (1.7 in)

Width: 21.7 cm (8.5 in)

Depth: 17.0 cm (6.7 in)

Weight: 0.5 kg (1.1 lb)

Standalone metal enclosure:

Height: 4.37 cm (1.7 in)

Width: 21.5 cm (8.4 in)

Depth: 15.3 cm (6.0 in)

Weight: 0.7 kg (1.5 lb)

Card: fits into the LRS-102 rack

Environment

Temperature: 0° to 55°C (32° to 131°F)

Extended temperature range

(standalone units in metal enclosures only): -20° to 65°C (-4° to 149°F)

Note: The extended temperature range for Optimux-108 with V.35 interface is 10° to 60°C (14° to 140°F.)

Humidity: Up to 90%, non-condensing

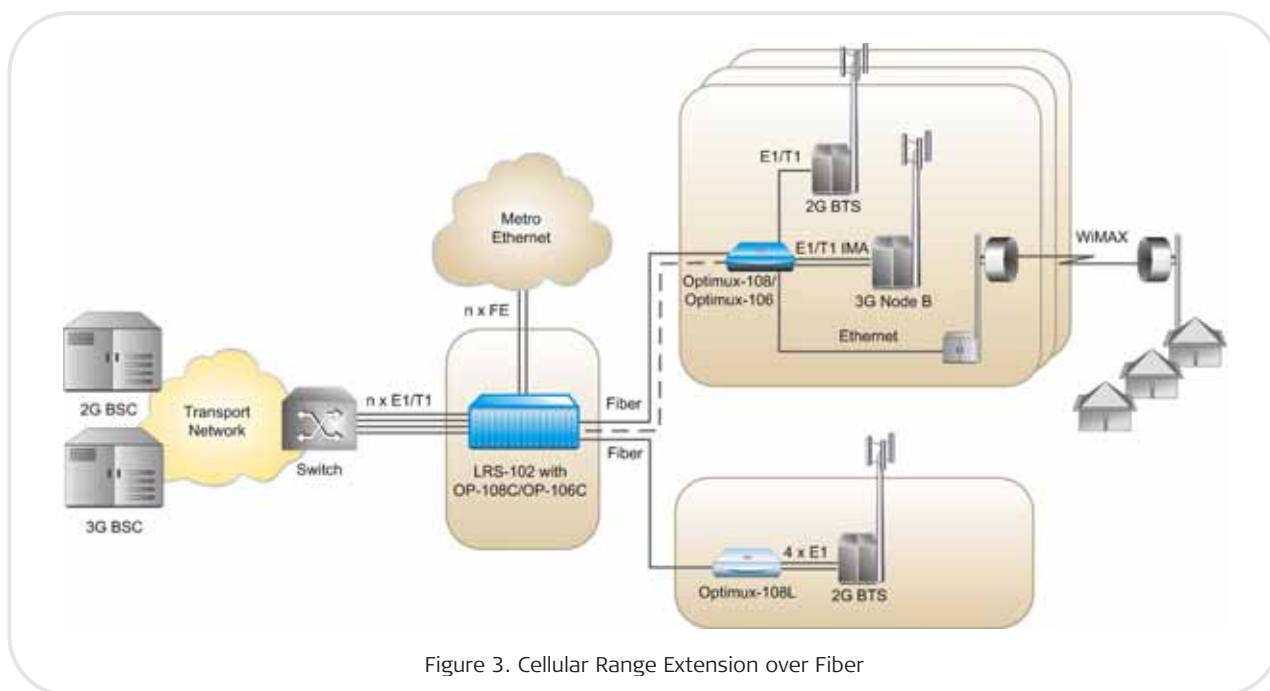

Figure 3. Cellular Range Extension over Fiber

Table 2. Optimux Comparison Table

Feature	OP-108L	OP-108/106	OP-134/125	OP-1032/1025	OP-45/45L	OP-1551	OP-1553
Uplink	Fiber Optic	Fiber Optic	E3, Fiber Optic	Fiber Optic	T3, Fiber Optic	Copper, STM-1/OC-3	Copper, STM-1/OC-3
Bandwidth (Mbps)	108	108/106	34/25 or 134/125	Proprietary	45	155	155
Number of trunks	4 E1	4 E1/4 T1	16 E1/16 T1	16 E1/16 T1	21 E1/28 T1	21/42/63 E1 28/56/84 T1	3 E3/3 T3
Ethernet support	✓	✓	✓	✓	-	-	-
Special features	Reduced power consumption cost-effective	Redundant, hot-swappable uplinks	Full bandwidth, Ethernet license activation	3xGbE User interfaces	Ring support (Optimux-45)	Full redundancy	Full redundancy
Card version for LRS-102/MP-4100	Works with OP-108C	✓	Works with OP-34C/OP-25C	-	-	-	-

Ordering

STANDARD CONFIGURATIONS

Standalone Units

OP-108/B/ETH/FC/13L
 OP-108/U/FC/13L
 OP-108/U/ETH/FC/13L/ME
 OP-108/B/ETH/SC/SF1
 OP-108/B/ETH/SC/SF2
 OP-106/ETH/ST/13L
 OP-106/SC/13L
 OP-106/SC/SF3
 OP-106/ETH/SC/13L
 OP-106/R/SC/13L

Card Modules

OP-108C/U/ETH/2XSFP10A
 OP-108C/U/ETH/2XSFP2
 OP-108C/B/ETH/2XSFP2
 OP-106C/ETH/SFP10B
 OP-106C/4XSFP24

SPECIAL CONFIGURATIONS - STANDALONE UNITS

OP-108/~/^/%/!/#!/+/\$/*/?

Fiber multiplexer for 4 E1 and Ethernet or serial data

OP-106/~/%/!/#!/+/\$/*/?

Fiber multiplexer for 4 T1 and Ethernet

Uplink modules

OP-108-M/#/+/\$/?
 OP-106-M/#/+/\$/?

Legend

~ Power supply (Default=AC/DC wide-range power supply):
24 24 VDC

^ E1 connector:

B Balanced (RJ-45)
U Unbalanced (BNC)

% Redundant power supply:
 (Default=one power supply)

R Redundant power supply of the same type (not for 24 VDC)

! Optional user port:
ETH 10/100BaseT Ethernet
V35 V.35 (Optimux-108 only)

Uplink interface connector
ST ST type connector
FC FC/PC type connector
SC SC type connector

Note: ST and FC connectors are not available for the single fiber options.

+ Fiber optic link interface:
85L 850 nm, multimode, VCSEL
13 1310 nm, multimode, LED

Note: Available with ST and SC connectors only.

13L 1310 nm, single mode, laser diode

15L 1550 nm, single mode, laser diode

13LH 1310 nm, single mode, long-haul laser diode

15LH 1550 nm, single mode, long-haul laser diode

SF1 Transmit 1310 nm laser (WDM), receive 1550 nm

SF2 Transmit 1550 nm laser (WDM), receive 1310 nm

SF3 Transmit and receive at 1310 nm laser diode

\$ Extended temperature version (Default=no extended temperature support):

H Extended temperature support (13L, 15L, 13LH, 15LH fiber link versions and metal enclosure only)

* Redundant uplink module (Default=single uplink)

D Second uplink module (of same type as first uplink module)

Note: For single fiber applications, a device with SF1 interface is always used opposite a device with SF2 interface, and vice versa. An SF3 interface works only opposite another SF3 interface.

? Enclosure (Default=plastic enclosure)
ME Metal enclosure

SUPPLIED STANDALONE ACCESSORIES

AC power cord
 DC adapter plug

CBL-MUSB-DB9F
 Control port cable

CBL-RJ45-DB9/F
 Alarm port cable

CBL-AMP-M34
 Cable to connect the Optimux-108 Smart Serial interface connector to the M34 connector of the user equipment.

OPTIONAL STANDALONE ACCESSORIES

CBL-AMP-DB25-ISO2110
 Cable to connect the Optimux-108 Smart Serial interface connector to the user equipment DB-25 connector with ISO 2110 pinout.

CBL-AMP-DB25-TLBS
 Cable to connect the Optimux-108 Smart Serial interface connector to the user equipment DB-25 connector with Telebras pinout.

RM-33-2
 Hardware kit for mounting one or two plastic units in a 19-inch rack

RM-35/@
 Hardware kit for mounting one or two metal units in a 19-inch rack

Legend

@ Rack mount kit (Default=both kits):

P1 Mounting one unit
P2 Mounting two units

WM-35-TYPE4

Hardware kit for mounting 8.5-inch units in metal enclosure

Optimux-108, Optimux-106

Fiber Multiplexer for 4 E1/T1 and Ethernet or Serial Data

SPECIAL CONFIGURATIONS - CARD MODULES FOR LRS-102

Note: For OP-108C/OP-106C cards operating in the Megaplex-4100 enclosure, refer to a separate OP-108C/OP-106C data sheet included into the Megaplex-4100 folder.

OP-108C/^/!/+

Dual fiber multiplexer module for 4 E1 and Ethernet

OP-106C!/+/

Dual fiber multiplexer module for 4 T1 and Ethernet

Legend

^ E1 connector:

B Balanced (RJ-45)

U Unbalanced (BNC connectors on a special LRS-102 rack, E1 only)

! Optional Ethernet user port:
(Default=no port)

ETH 10/100BaseT Ethernet port

+ SFP fiber optic link interface:

SFP1 LED, 1310 nm, multimode, LC only

SFP2 Laser, 1310 nm, single mode, LC only

SFP2H SFP2 in Extended temperature version

SFP3 Long-haul laser, 1310 nm, single mode, LC only

SFP3H SFP3 in Extended temperature version

SFP4 Long-haul laser, 1550 nm, single mode, LC only

SFP10A Laser WDM, Tx - 1310 nm, Rx - 1550 nm, single mode, single fiber, LC only (SF1)

SFP10B Laser WDM, Tx - 1550 nm, Rx - 1310 nm, single mode, single fiber, LC only (SF2)

SFP18A Laser WDM, Tx - 1310 nm, Rx - 1550 nm, single mode, single fiber, LC only

SFP18B Laser WDM, Tx - 1550 nm, Rx - 1310 nm, single mode, single fiber, LC only

SFP24 VSCEL, 850 nm, multimode, LC only

2XSFP1 Dual SFP1 modules

2XSFP2 Dual SFP2 modules

2XSFP2H Dual SFP2H modules

2XSFP3 Dual SFP3 modules

2XSFP3H Dual SFP3H modules

2XSFP4 Dual SFP4 modules

2XSFP10A Dual SFP10A modules

2XSFP10B Dual SFP10B modules

2XSFP18A Dual SFP18A modules

2XSFP18B Dual SFP18B modules

2XSFP24 Dual SFP24 modules

4XSFP1 Quad SFP1 modules

4XSFP2 Quad SFP2 modules

4XSFP2H Quad SFP2H modules

4XSFP3 Quad SFP3 modules

4XSFP3H Quad SFP3H modules

4XSFP4 Quad SFP4 modules

4XSFP10A Quad SFP10A modules

4XSFP10B Quad SFP10B modules

4XSFP18A Quad SFP18A modules

4XSFP18B Quad SFP18B modules

4XSFP24 Quad SFP24 modules

Notes: 1. It is strongly recommended to order this device with original RAD SFPs installed. This will ensure that prior to shipping, RAD has performed comprehensive functional quality tests on the entire assembled unit, including the SFP devices. RAD cannot guarantee full compliance to product specifications for units using non-RAD SFPs.

2. For single fiber applications, a device with SFP-10A interface is always used opposite a device with SFP-10B interface, and vice versa.

OPTIONAL CARD ACCESSORIES

CBL-G703-8/RJ45/ST

Adapter cable to split the 44-pin card connector to 8 E1 or T1 balanced RJ-45 connectors

CBL-G703-8/RJ45/X

Splitter cross-cable for splitting the 44-pin card connector to 8 E1 or T1 balanced RJ-45 connectors

CBL-G703-8/COAX

Splitter cable for splitting the 44-pin OP-108C card connector to 8 pairs of unbalanced BNC connectors

CBL-G703-8/OPEN/2M

Open-ended cable with DB-44 connector on the LRS-102 side for balanced E1 or T1 applications

All cables are 2m (6.6 ft) long.

International Headquarters
24 Raoul Wallenberg Street
Tel Aviv 69719, Israel
Tel. 972-3-6458181
Fax 972-3-6498250, 6474436
E-mail market@rad.com



12 avenue des prés
78059 St Quentin en Yvelines
Tel: 33 (0)1 77 55 03 00
Fax: 33 (0)1 30 44 11 95
E-mail: sales@cbnetworks.fr



data communications
The Access Company