

SPH-16

SFP Patching Hub



Converting Ethernet copper ports to SFP sockets

- Converts 16 Fast Ethernet or Gigabit Ethernet copper ports to SFP sockets
- Supports any third-party standard SFP device
- Fully transparent Layer 1 wire-speed conversion eliminates store and forward delays
- Provides fault propagation to LAN link
- Supports SNMP management to interface with I²C parameters of standard SFP devices

SPH-16 is a simple, smart and powerful patching hub that converts Ethernet copper ports to SFP sockets.

The device can connect to any RJ-45 compatible switch and supports RAD's System on an SFP family of products, MiRiCi and MiTOP. It also supports standard SFP devices from any other vendor.

SPH-16 can also be used as an Ethernet copper-to-fiber converter, with various fiber optic media, to extend the distance of Fast Ethernet and Gigabit Ethernet networks.

The device supports hot-swappable SFPs working at 100 Mbps and 1000 Mbps, as well as Ethernet copper ports working at 100 Mbps and 1000 Mbps. It also supports hot-swappable AC and DC power supplies. Auto-discovery of Fast Ethernet (100 Mbps) or Gigabit Ethernet (1000 Mbps) is supported.

SPH-16 provides a flexible lower-cost alternative to being locked into purchasing expensive dedicated SFPs.



SPH-16

SFP Patching Hub

FAULT PROPAGATION

If a failure is detected on the SFP port, the fault propagation mechanism deactivates the Ethernet copper port.

FLEXIBILITY

The SPH-16 ports can be used for any combination of 100 Mbps or 1000 Mbps fiber optic SFPs and the RAD products MiRiCi and MiTOP.

MANAGEMENT

The unit can be managed via:

- ASCII terminal, for configuration and status
- PC running a WEB browser
- Telnet host
- SNMP-based network management station.

SECURITY

SPH-16 supports the following security protocols, to provide a high level of communication security:

- SNMPv3
- RADIUS authentication
- SSL for Web-based management
- SSH for Secure Shell communication.

DIAGNOSTICS

Comprehensive diagnostic capabilities include real-time major and minor alarms to alert the user to fault conditions.

POWER SUPPLY REDUNDANCY

SPH-16 offers the option of redundant power supplies, increasing reliability.

COMPACT SIZE

The unit is supplied in a compact 19-inch 1U high enclosure.

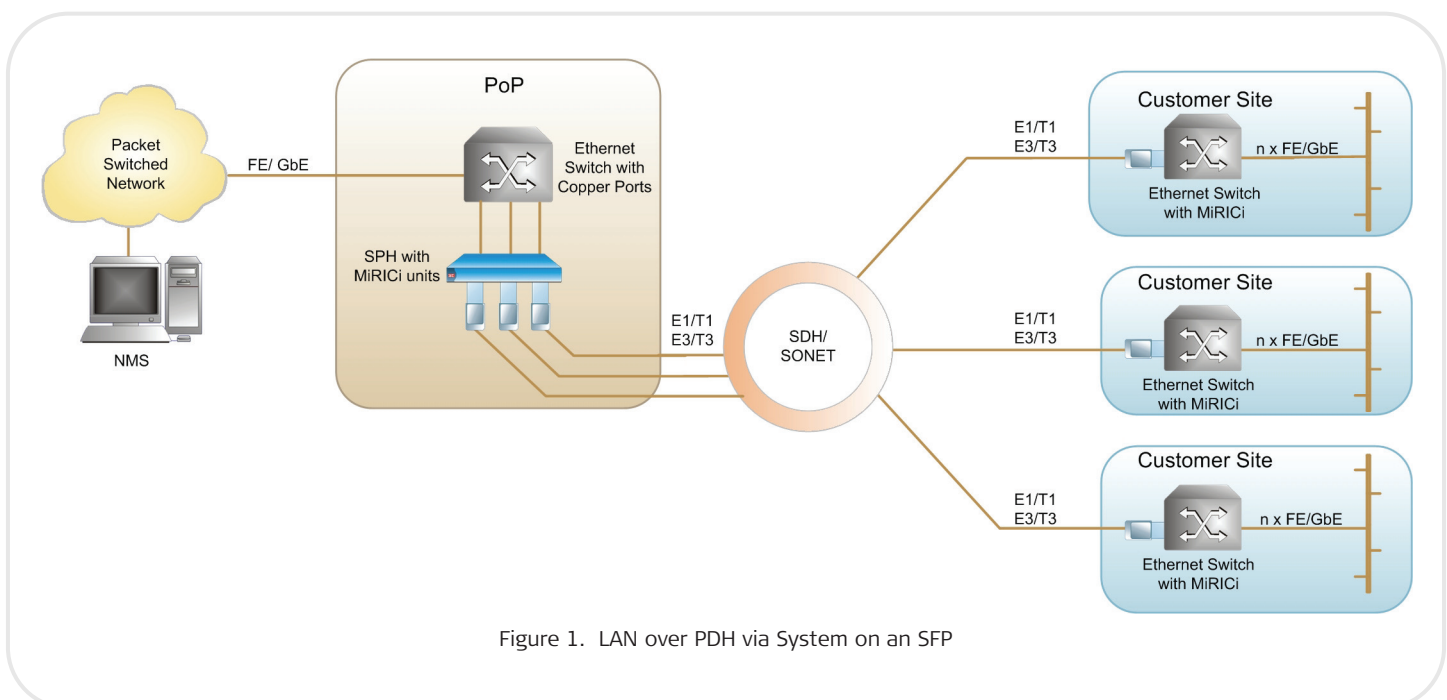

Figure 1. LAN over PDH via System on an SFP

Specifications

ETHERNET USER INTERFACE

Number of Ports

16

Compliance

IEEE 802.3

Type

100/1000 Mbps, autonegotiation, full-duplex, MDI/MDX crossover

Maximum Frame Size

10,000

Line Impedance

100Ω

Connector

RJ-45, shielded

SFP USER INTERFACE

Number of ports

16

Data rate

100/1000Mbps

Maximum Frame Size

10,000

Interface Type

Giga SERDES or 100BaseFX

Connector

SFP-based, MSA compliant

MANAGEMENT PORTS

Out-of-Band Ethernet Management Port

Compliance: IEEE 802.3

Type: 10/100 Mbps, MDI/MDX crossover

Maximum Frame Size: 1522

Connector: RJ-45, shielded

Control Port

Interface: RS-232 DCE

Connector: DB-9, female

Data rate: 9.6, 19.2, or 115.2 kbps

INDICATORS

Ethernet Copper User (per port)

LINK/ACT (yellow) – LAN link and data activity status

On: Ethernet link is up

Off: Ethernet link is not up

Flashing: Ethernet link is up and RX and/or TX frames are being transmitted

100/1000 (green) – 100 or 1000 Mbps

On: 1000 Mbps mode

Off: 100 Mbps mode

SFP User (per port)

LINK/ACT (yellow) – Ethernet link integrity and data activity status

On: Ethernet link is up

Off: Ethernet link is not up

Flashing: Ethernet link is up and Rx and/or Tx frames are being transmitted

Ethernet Management

LINK/ACT (yellow) – LAN link and data activity status

On: Ethernet link is up

Off: Ethernet link is not up

Flashing: Ethernet link is up and RX and/or TX frames are being transmitted

10/100 (green) – 10 Mbps or 100 Mbps

On: 100 Mbps mode

Off: 10 Mbps mode

GENERAL

Power

AC power supply:

100–240 VAC ±10%, 50/60 Hz

DC power supply: 20–72 VDC

Power Consumption (fully occupied)

AC: 105 VA

DC: 70 W

Physical

Height: 43.7 mm (1.7 in) 1U

Width: 440 mm (17.3 in)

Depth: 182 mm (7.2 in)

Weight: 2.9 kg (6.4 lb)

Environment

Temperature: 0 – 50°C (32–122°F)

Humidity: Up to 90%, non-condensing

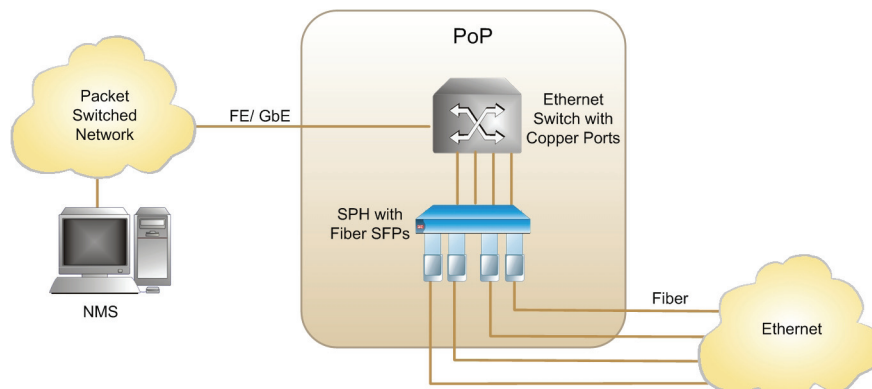

Figure 2. Ethernet Copper to Fiber

SPH-16

SFP Patching Hub

Ordering

SPH-16/#/RM

Legend

Power supply:

- AC** single 100 to 240 VAC
- DC** single 20 to 72 VDC
- ACR** dual 100 to 240 VAC
- DCR** dual 20 to 72 VDC

RM Rack mounting equipment

(Default=None):

- CT** Cable tray with rack mount
(19-inch non-ETSI)

SUPPLIED ACCESSORIES

AC power cord (with AC power supply only)

DC connection kit (with DC power supply only)

OPTIONAL ACCESSORIES

RM-43

Hardware kit for mounting one SPH-16 unit in an ETSI rack (including cable tray)

RM-43-19

Hardware kit for mounting one SPH-16 unit in a 19-inch non-ETSI rack (including cable tray)

RM-43-19-H1

Hardware kit for mounting one SPH-16 unit in a 19-inch non-ETSI rack

International Headquarters

24 Raoul Wallenberg Street
Tel Aviv 69719, Israel
Tel. 972-3-6458181
Fax 972-3-6498250, 6474436
E-mail market@rad.com



12 avenue des prés
78059 St Quentin en Yvelines

Tel: 33 (0)1 77 55 03 00
Fax: 33 (0)1 30 44 11 95

E-mail: sales@cbnetworks.fr



data communications

The Access Company