

FCD-E1M, FCD-T1M



Modular E1/T1 or Fractional E1/T1 Access Units Supporting Megaplex-2100 Modules



FEATURES

- E1/T1 or Fractional E1/T1 access units
- Optional sub-E1/T1 drop-and-insert port for PBX connectivity
- Single slot supports Megaplex-2100 I/O modules
- Fail-safe sub-E1/T1 link ensures uninterrupted service
- One data port with selectable sync data rates: $n \times 56$, $n \times 64$ kbps
- Data interfaces: RS-530, V.35, V.36/RS-449, or X.21
- Optional high-performance Ethernet bridge/router
- SNMP agent
- Out-of-band management via V.24 supervisory port or Ethernet management port
- Inband management via TS 0 or dedicated timeslot
- Dial-in option for remote out-of-band management
- Dial-out for alarm report
- The E1/T1 main link can be supplied with the following options:
 - Copper interface with built-in software-selectable LTU for E1 and CSU for T1
 - Fiber optic interface
- Enhanced diagnostics include:
 - User activated local and remote loopbacks
 - Integrated BER tester
 - Fractional E1/T1 inband loop
- Store 24 hours of E1/T1 network performance monitoring and last 100 alarms
- Relay activation upon alarm event
- Alarm mask configurable for any alarm

DESCRIPTION

- FCD-E1M and FCD-T1M serve as access multiplexers, to provide business customers with modular integration of voice and data traffic over E1/T1 or Fractional E1/T1 services (see *Figure 1*).
- The units also operate opposite RAD's modular DXC multiservice access node or other vendors' E1/T1 equipment, for multilink star applications, such as access to SDH networks. The DXC and FCD units operate together with centralized SNMP network management (see *Figure 2*).
- The devices can be ordered with a copper E1/T1 or a fiber optic link. Both configurations are also available with an optional copper sub-E1 drop-and-insert port. The units include a single data port, or an Ethernet bridge with or without VLAN support, or an Ethernet router.
- FCD-E1M and FCD-T1M include a single I/O module slot that supports one Megaplex I/O module. This provides field upgrade and service profile change capabilities that are usually available only on larger modular devices. For supported module details and ordering information, see individual module data sheets.

FCD-E1M, FCD-T1M

Modular E1/T1 or Fractional E1/T1 Access Units Supporting Megaplex-2100 Modules

BASIC UNIT

- The basic unit contains a power supply, a copper E1/T1 link, one data port, and single a slot for a Megaplex-2100 I/O module. The sublink and Ethernet bridge/router are optional.
- The E1 interface is compatible with most carrier-provided E1 services and meets ITU recommendations G.703, G.704, G.706, and G.732. The E1 interface supports either 2 or 16 frames per multiframe, with or without CRC-4. The main link also operates in unframed mode to generate an unframed signal. Line code is HDB3. The integral LTU (soft-selectable) ensures a range of up to 2 km (1.2 miles).
- The T1 interface is compatible with most carrier-provided T1 services and complies with TR-62421. The T1 interface supports D4 and ESF framed formats. The main link operates in unframed mode to generate an unframed signal. Zero suppression over the line is selectable for either transparent, B7ZS, or B8ZS. The integral soft-selectable CSU ensures a range of up to one mile.
- FCD-E1M and FCD-T1M can be ordered with a fiber optic main link to eliminate the need for an external fiber optic modem. The fiber optic link provides a secure link in hazardous or hostile environments with greater range. It complies with ITU standards G.921 and G.956.

- Three fiber optic interfaces are available:
 - 850 nm laser for use over multimode fiber at distances of up to 5 km (3 miles)
 - 1310 nm laser diode for use over single-mode fiber at distances of up to 62 km (38 miles)
 - 1550 nm laser diode for use over single-mode fiber at extended range of up to 100 km (62 miles).
- Timeslot assignment is programmable to allow data from each data port and from the sublink to be placed either automatically into consecutive timeslots, or manually, according to user discretion.
- Multiple clock source selection ensures maximum flexibility for supporting different applications. The E1 main link may derive its timing from the recovered receive clock, from an internal oscillator, from one of the data ports, or from the sub-E1 port.
- Bypassing the sublink to the main link (other than fiber optic) ensures uninterrupted service to the sub-E1/T1 port and provides immunity to hardware and power failure.
- FCD-E1M and FCD-T1M are standalone units. A rack mount adapter kit allows installation of one unit in a 19-inch rack.

USER INTERFACE

- The following data port interfaces can be ordered: V.35, RS-530, V.36/RS-449, or X.21. The ports operate in the following clock modes:
 - **DCE:** The FCD units provide the transmit and receive clocks to the user equipment, with an option to sample the incoming data with an inverted clock
 - **DTE1:** The external transmit clock is taken from the user DTE
 - **DTE2:** Both the transmit and receive clocks are taken from the user DTE.
- When equipped with IR-ETH or IR-ETH/Q bridge options, FCD-E1M and FCD-T1M transparently connect remote LANs over unframed E1/T1 links to utilize the full E1/T1 bandwidth. The bridges filter Ethernet frames and forward only frames destined to the WAN. The IR-ETH/Q bridge also supports VLANs.
- The optional built-in Ethernet router is a high-performance remote IP router. It is ideal as a LAN extender or segmenter over bit-stream type infrastructures. The router receives Ethernet packets from the LAN and forwards them to the IP network on the Ethernet LAN or to the WAN by destination.
- The optional sub-E1 port can be configured to work without CRC-4, while the E1 main link works with CRC-4. This enables non-CRC-4 equipment to connect to a CRC-4 E1 network.
- The optional sub-T1 port can be configured with D4 or ESF framing, while the T1 main link uses ESF framing. This allows connection of T1 D4 equipment over a T1 network.

APPLICATIONS

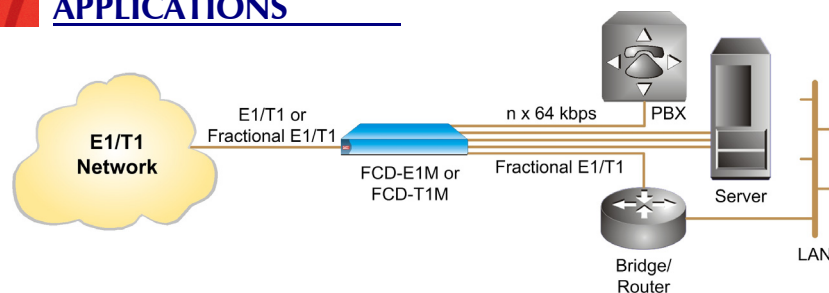

Figure 1. LAN and PBX Traffic over an E1/T1 Network



FCD-E1M Rear Panel

FCD-E1M, FCD-T1M

Modular E1/T1 or Fractional E1/T1 Access Units Supporting Megaplex-2100 Modules

MANAGEMENT AND MAINTENANCE

- Setup, control and monitoring of status and diagnostics information can be activated via:
 - ASCII terminal connected to the async control port command line interpreter
 - SNMP management connected to the async control port.
- FCD-E1M and FCD-T1M have an internal SNMP agent and can be controlled by any generic SNMP station or by the GUI-based RADview SNMP network management application.
- FCD-E1M and FCD-T1M support dial-in and dial-out modem connections. These connections can be used for remote out-of-band configuration, monitoring and for sending callout alarm messages using serial V.24 SLIP, PPP, or Ethernet ports.
- Inband management on the FCD-E1M can be performed by using the spare bits (Sa bits) on TS 0 or by using a dedicated timeslot using standard protocols, Frame Relay (RFC 1490), PPP, and standard RIP2 routing. This allows setup, monitoring and diagnostics of the remote unit. Inband access using spare bits on TS 0 is possible only if those bits are transparently passed end-to-end.
- Inband management on the FCD-T1M can be performed by using the Facility Data Link (FDL) in the ESF framing format or by using a dedicated timeslot. This allows setup, monitoring and diagnostics of the remote unit. Inband access using the FDL is possible only if the FDL is transparently passed end-to-end.
- Maintenance capabilities include user-activated local and remote loopbacks on the E1/T1 main link, sub-E1/T1, and data ports.
- The user can activate a BER test for each data or sub-E1/T1 port, individually. Each data or sub-E1/T1 port responds to an ANSI FT1 RDL (T1E1.2/93-003) inband loop code, generated by the remote FCD-E1M/FCD-T1M, DXC, or dedicated test equipment in a specific bundle of timeslots allocated only to that port. In addition, FCD-T1M responds to network activated loops (PLB, LLB) when configured as CSU.
- When operating with CRC-4, E1 network statistics are stored in memory according to RFC-1406. Statistical information may be retrieved locally through the control port.
- When operating in the ESF format, T1 network statistics are stored in memory according to ANSI and AT&T standards. Statistical information may be retrieved by the service provider (ANSI only) or locally through the control port.

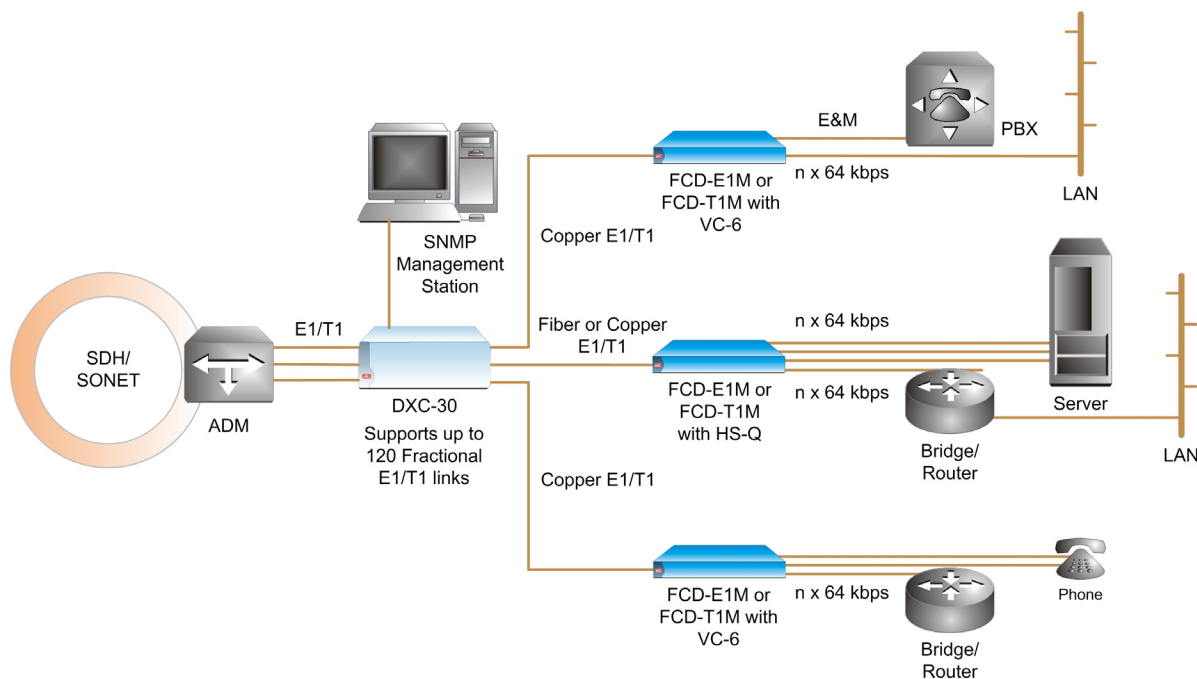

Figure 2. SDH Access Solution for Multiple Remote Sites

FCD-E1M, FCD-T1M

Modular E1/T1 or Fractional E1/T1 Access Units Supporting Megaplex-2100 Modules

SPECIFICATIONS

E1/T1 MAIN LINK AND SUBLINK

- **E1 Framing**
 - 256N (no MF, CCS)
 - 256N with CRC-4 (no MF, CCS)
 - 256S (TS16 MF, CAS)
 - 256S with CRC-4 (TS16 MF CAS)
 - Unframed (main link only)
- **T1 Framing**
 - D4
 - ESF
 - Unframed (main link only)
- **Bit Rate**
 - E1: 2.048 Mbps
 - T1: 1.544 Mbps
- **Line Code**
 - E1: HDB3
 - T1: AMI
- **T1 Zero Suppression**
Transparent, B7ZS, B8ZS
- **E1 Signal Level**
 - Receive:
 - 0 to -36 dB with LTU (main link only)
 - 0 to -10 dB without LTU
 - Transmit:
 - ±3V (±10%), balanced
 - ±2.37V (±10%), unbalanced
- **T1 Signal Level**
 - Receive:
 - 0 to -36 dB with CSU (main link only)
 - 0 to -10 dB without CSU
 - Transmit:
 - 0, -7.5, -15, -22.5 dB with CSU
 - ±3V, ±10% soft adjustable at 0 to 655 ft without CSU

- **Line Impedance**
 - E1: 120Ω, balanced and 75Ω, unbalanced
 - T1: 100Ω, balanced
- **Connectors**
 - E1: RJ-45, 8-pin, balanced
 - T1: RJ-45, 8-pin, balanced
- **Main Link Timing**
 - Internal accuracy: ±30 ppm
 - Loopback timing: ±130 ppm
 - Sub-E1: 2.048 Mbps ±130 ppm
 - Sub-T1: 1.544 Mbps ±130 ppm
 - External timing from data port:
 - n × 56, n × 64 ±130 ppm
- **Sublink Timing**
Locked to the main link
- **Compliance**
 - E1: ITU G.703, G.704, G.706, G.732, G.823
 - T1: AT&T TR-62411, TR-62421
ANSI T1.403, AT&T 54016 (local support)
- **E1 Jitter Performance**
 - Per ITU G.823
 - ETSI TBR-12 and TBR-13
- **T1 Jitter Performance**
As per AT&T TR-62411

FIBER OPTIC MAIN LINK

- **Compliance**
G.921, G.956
- **Transmitter Type**
Laser
- **Operating Characteristics**
See Table 1.
- **Connectors**
ST, FC/PC or SC (see *Ordering*)

DATA PORT

- **Number of Data Ports**
One

- **Interface**
RS-530, V.35, V.36/RS-449, X.21
- **Connectors**
D-type 25-pin, female, RS-530 pinout
- **Data Rate**
n × 56 or n × 64 kbps, (n=1–31)
- **Clock Modes**
DCE: Rx and Tx clock to DTE
DTE1: Rx clock to user device;
Tx clock from user device
DTE2: Rx and Tx from DCE
- **Control Signals**
 - CTS follows RTS or constantly ON, soft-selectable
 - DSR constantly ON, unless in test mode
 - DCD constantly ON, unless in RED ALARM

ETHERNET BRIDGE/ROUTER PORT

See Table 2.

- **Connectors**
10BaseT (UTP): Shielded RJ-45

GENERAL

- **Diagnostics**
Main E1/T1 link:
Local and remote loopback
Sub-E1/T1 port:
 - Local and remote loopback
 - Sub-E1/T1 port BER test
 Data port:
 - Local data port loopback
 - Remote data port loopback
 - Data port BER test
 - Inband code activated loopback per data port
 - T1 network loopback, code-activated (FCD-T1M only)
- **Timeslot Allocation**
 - Automatic (bundled) in consecutive timeslots
 - User-defined
- **Performance Monitoring**
E1 Main Link
 - Local support of CRC-4
 - Statistics according to RFC-1406**T1 Main Link**
 - Local support of ESF diagnostics according to AT&T PUB 54016
 - Full statistical diagnostics according to ANSI T1.403-1989

Table 1. Fiber Optic Interface Characteristics

Wavelength [nm]	Fiber Type [μm]	Typical Output Power [dBm]	Receiver Sensitivity [dBm]	Maximum Range	
				[km]	[mi]
850	62.5/125 multimode	-16	-38	5	3
1310	9/125 single mode	-12	-39	62	38
1550	9/125 single mode	-12	-39	100	62

FCD-E1M, FCD-T1M

Modular E1/T1 or Fractional E1/T1 Access Units Supporting Megaplex-2100 Modules

- **Control Port (DCE)**
 - Interface: V.24/RS-232
 - Connector: 9-pin D-type, female
 - Format: asynchronous
 - Baud rate: 1.2 to 19.2 kbps, autobaud
 - Character: 8 bit no parity, 7 bit odd or even parity
- **Indicators**
 - General: PWR (green), TST (yellow), MAJ ALM (red), MIN ALM (red)
 - Main E1 and Sub-E1: LOC SYNC LOSS (red), REM SYNC LOSS (red)
 - Main T1 and Sub-T1: RED SYNC LOS (red), YEL SYNC LOS (yellow)
- **Alarms**

Last 100 alarms are stored and available for retrieval. Each alarm is time stamped.
- **Alarm Relay**

3 relay contacts are available on the control DTE port. The alarm relay is activated by alarms in the alarm buffer.
- **Physical**

Height: 43.7 mm (1.7 in)
 Width: 44.4 cm (17.3 in)
 Depth: 24.3 cm (9.5 in)
 Weight: 1.3 kg (2.9 lb)
- **Power**

100–240 VAC; 47–63 Hz
 -48 VDC, nominal (40-57 VDC)
 Power consumption: 6W
- **Environment**

Temperature: 0°–50°C (32°–122°F)
 Humidity: up to 90%, non condensing

ORDERING

- FCD-E1M*/~/~/\$/&/#+**
 Modular E1/Fractional E1 access unit
- FCD-T1M*/~/~/\$/&/#+**
 Modular T1/Fractional T1 access unit
- * Specify **S1** for optional drop-and-insert copper E1/T1 sublink
 - ~ Specify power supply voltage:
AC for 100 to 240 VAC
48 for -48 VDC
 - \$ Specify management port interface:
V24 for V.24/RS232 (DB-9)
UTP for Ethernet 10BaseT (UTP)
 - & Specify data port interface option:
530 for RS-530
V35 for V.35
X21 for X.21
V36 for V.36/RS-449
ETUB for IR-ETH UTP Ethernet bridge (10BaseT)
ETUQ for IR-ETH/Q UTP Ethernet bridge with VLAN support (10BaseT)
ETUR for IR-IP UTP Ethernet router (10BaseT)
 - # Specify link connector type:
ST for ST connector
SC for SC connector
FC for FC/PC connector (Default is for G.703 copper interface)
 - + Specify optional optical interface wavelength/transmitter type:
85 for 850 nm laser, multimode
13L for 1310 nm laser, single mode
15L for 1550 nm laser, single mode

SUPPLIED ACCESSORIES

- AC power cord (when AC power supply is ordered)
- DC adapter plug (when DC power supply is ordered)
- The following cables (suitable for use in DCE clock mode only) are supplied for each data port interface specified. Cable length is 2m (6 ft):

CBL-HS2/V/1/# for 34-pin V.35, DCE
CBL-HS2/R/1/# for 37-pin V.36, DCE
CBL-HS2/X/1/# for 15-pin X.21, DCE

OPTIONAL ACCESSORIES

- RM-34**
 Hardware kit for mounting one unit in a 19-inch rack
- CBL-HS2*/*/#**
 Adapter cables for DB-25 channel connectors. Cable length is 2m (6 ft).
- * Specify interface, clock mode:
V/2/# for 34-pin V.35, DTE1
V/3/# for 34-pin V.35, DTE2
R/2/# for 37-pin V.36/RS-449, DTE1
R/3/# for 37-pin V.36/RS-449, DTE2
- # Specify cable connector type:
F for female
M for male

Table 2. Ethernet Interface Modules Characteristics

Interface Module	LAN Table [addresses]	Filtering and Forwarding [fps]	Buffer [frames]	Delay [frames]	Line Code	WAN Protocol
IR-ETH	10,000	15,000	256	1	Manchester	HDLC
IR-ETH/Q	2,000	2,000	256	1	Manchester	HDLC
IR-IP	–	–				

Note: All the Ethernet interface modules support IEEE 802.3. Additionally, IR-ETH/Q supports IEEE 802.3u.



12 avenue des prés
 78059 St Quentin en Yvelines
 Tel: 33 (0)1 77 55 03 00
 Fax: 33 (0)1 30 44 11 95
 E-mail: sales@cbnetworks.fr



data communications

www.rad.com

- **International Headquarters**
 24 Raoul Wallenberg Street
 Tel Aviv 69719, Israel
 Tel: 972-3-6458181
 Fax: 972-3-6498250
 Email: market@rad.com
- **North America Headquarters**
 900 Corporate Drive
 Mahwah, NJ 07430, USA
 Tel: (201) 529-1100
 Toll free: 1-800 444-7234
 Fax: (201) 529-5777
 Email: market@radusa.com

176-100-01/06