

FCD-IP

E1/T1 or Fractional E1/T1 Access Unit with Integrated Router



Integrated access device providing bundled services over E1/T1 access lines

- Provides bundled services (data, IP, and telephony) over E1/T1 access lines
- E1/T1 uplink over copper or fiber optic media
- Operates opposite RAD's DXC cross-connect system and Megaplex access multiplexers
- Supports Frame Relay, PPP, and MLPPP

FCD-IP is an E1/T1 or fractional E1/T1 integrated access device (IAD), which enables service providers to bundle data, voice, and IP access services over a single E1 or T1 access line (see *Figure 1*).

Supported WAN services are:

- T1 or fractional T1 CSU/DSU operating at rates of up to 1.544 Mbps
- E1 or fractional E1, with or without LTU, operating at rates of up to 2.048 Mbps
- E1 or T1 over fiber optic links

- Frame Relay with auto-learn of DLCI and maintenance protocol
- ISDN BRI ("U" or "S" interface) for data services backup.

An integrated router supports IP routing and transparent bridging.

An optional internal 4-port Ethernet/Fast Ethernet switch can be installed in place of LAN ports.

Internet/intranet access capabilities are enhanced through:

- **IP Service Access** authentication provided by PAP/CHAP



FCD-IP

E1/T1 or Fractional E1/T1 Access Unit with Integrated Router

- **Solid Firewall** that protects an office LAN from undesired entry from the Internet
- **NAT** that allows the sharing of several legal IP addresses between the various LAN users
- **Single IP** address translation that allows a small or medium office LAN to connect to the Internet using a single dynamically or statically allocated IP address
- **DHCP** server that allows the sharing of ISP address pools between DHCP clients on the LAN.
- **OSPF** protocol based on the link state technology, distributing information about the state of links between routers.

The sub-E1/T1 or quad analog voice drop-and-insert ports provide toll-quality voice transmission. Up to three sub-E1/T1 ports can be installed in FCD-IP, aggregating three fractional E1s into one full E1 stream (see *Figure 2*).

In the ring (*Figure 3*) and daisy-chain and shared LAN applications (*Figure 4*), the first sub-E1/T1 port (sub1-E1/T1) can be used as a main link. In this case some of the E1/T1 timeslots pass through internal routers of all FCD-IP devices used in the application. The other timeslots are dropped at the user interfaces (FXS, remaining sub-E1/T1 ports etc). This enables the units to drop and insert timeslots and take routing decisions at any FCD-IP.

Notes: *The sub1-E1/T1 port cannot be defined as a main link if FCD-IP includes a DTE data port, two LAN ports or ISDN ports.*

FCD-IP connected to two LANs cannot be used in the ring applications.

The fail-safe bypass of the sub1-E1/T1 link ensures the continuity of voice services in case of power supply failures. The bypass is not available for the fiber optic main links.

ISDN or PSTN backup, using an external dial-up modem, ensures the continuity of data services.

An optional data port can be utilized either as a second serial router port or as a transparent $n \times 64$, $n \times 56$ data port for connecting legacy equipment.

The unit can be easily configured through a quick setup menu using a terminal attached to the control port or by Telnet access over the LAN/WAN.

FCD-IP features a variety of inband and out-of-band management options. These options include dedicated timeslot, dedicated DLCI and dial-in.

The SNMP agent provides management by RADview or any other standard SNMP management station.

Undesired access to FCD-IP via Telnet or SNMP can be blocked or password protected.

The dual-level management authentication allows user access to router configuration parameters, while restricting user access to network configuration parameters.

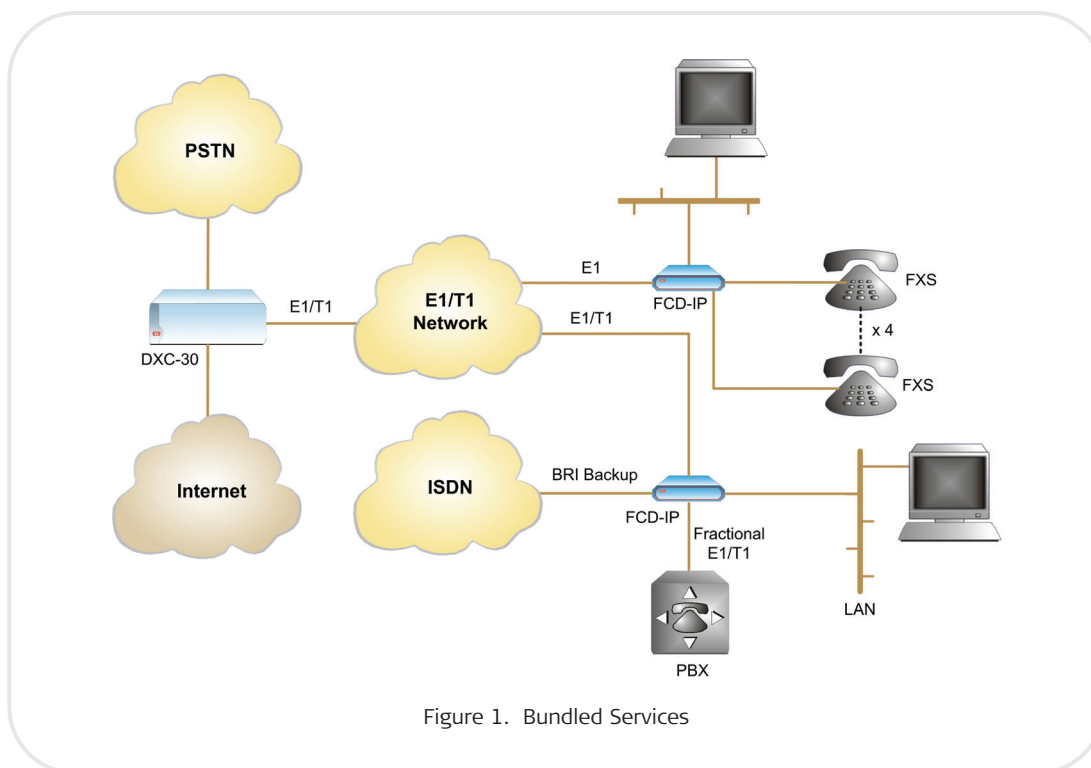

Figure 1. Bundled Services

Software download is available via the control port using XMODEM and via LAN/WAN using TFTP.

Parameter file download and upload is available via LAN or WAN using TFTP.

Specifications

E1 INTERFACE

Framing

G732N (no MF, CCS)
G732N (no MF, CCS) with CRC-4
G732S (TS16 MF, CAS)
G732S (TS16 MF CAS) with CRC-4

Bit Rate

2.048 Mbps

Line Code

AMI

Zero Suppression

HDB3

Impedance

120Ω, balanced
75Ω, unbalanced

Signal Level

Receive:
0 to -36 dB with LTU
0 to -12 dB without LTU
Transmit:
3V (±10%), balanced
2.37V (±10%), unbalanced

Jitter Performance

As per ITU G.823

Connectors

RJ-45, balanced or two BNC coaxial, unbalanced (via adapter cable)

Compliance

ITU G.703, G.704, G.706, G.732

Diagnostics

User-activated local and remote loopbacks

T1 INTERFACE

Framing

D4, ESF

Bit Rate

1.544 Mbps

Line Code

AMI

Zero Suppression

Transparent, B7ZS, B8ZS

Impedance

100Ω, balanced

Signal Level

Receive:
0 to -36 dB with CSU
0 to -15 dB without CSU
Transmit:
0, -7.5, -15, -22.5 dB with CSU
Soft adjustable at 0 to 655 ft, without CSU

Jitter Performance

As per AT&T TR-62411

Connector

RJ-45 8-pin, balanced

Compliance

AT&T TR62411, ANSI T1.403

Diagnostics

User activated local and remote loopbacks
Network activated loopbacks and FDL loopbacks (RLB, LLB)

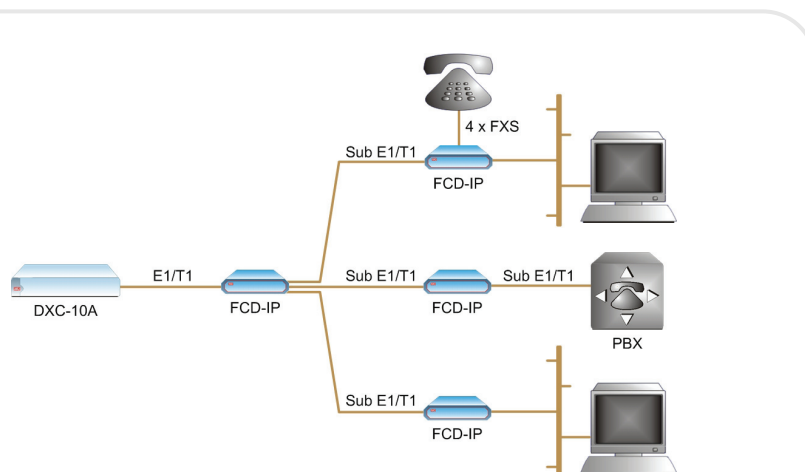

Figure 2. Aggregating Three Fractional E1 Links into One Full E1 Link

ANALOG VOICE INTERFACE

Number of Channels

Four

Modulation Method

PCM (per ITU-T G.711 and AT&T PUB-43801), μ -Law or A-Law

INTERFACES

E&M:

2-wire or 4-wire, supporting different types of E&M signaling: RS-464 Types I, II, III and V, and BT SSDC5, software-configured

FXS:

Loop start, WINK start (reverse polarity) for direct connection to a 2-wire telephone, CID (Caller ID) support

FXO:

Loop start, WINK start (reverse polarity) connection to a 2-wire telephone exchange subscriber line

Nominal level: 0 dBm

Nominal impedance: 600 Ω

Return loss: (ERL), better than 20 dB

Frequency response (Ref: 1020 Hz):

± 0.5 dB, 300 to 3000 Hz

± 1.1 dB, 250 to 3400 Hz

Signal to total distortion, G.712, G.713 method 2:

0 to -30 dBm0, better than 33 dB

+3 to -45 dBm0, better than 22 dB

Idle channel noise: Better than

-70 dBm0 (+20 dBnc)

Transformer isolation: 1500 VRMS

DIAGNOSTICS

Local digital loopback towards the analog side

Remote analog loopback towards the remote side, activated from the local side

1 kHz tone injection towards the analog side

Connectors

E&M: RJ-45, 8-pin

FXS, FXO: RJ-11, 6-pin

ISDN INTERFACE

Interface

ISDN BRI, "S" and "U"

Compliance

ETS 300012, I.430, NTT, 5ESS, DMS-100, NI1

LAN INTERFACE

Number of Ports

1, 2, or 4

Compliance

IEEE 802.3

Type

Single 10/100BaseT (RJ-45) port

Dual 10BaseT (RJ-45)

4-port 10/100BaseT (RJ-45) switch

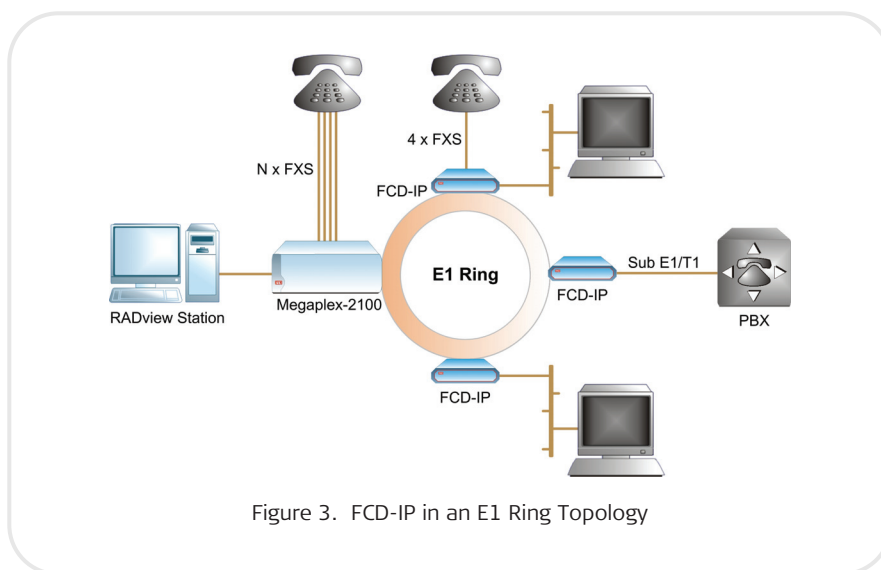

Figure 3. FCD-IP in an E1 Ring Topology

FCD-IP

E1/T1 or Fractional E1/T1 Access Unit with Integrated Router

DATA PORT INTERFACE

Type and Connectors

RS-232/V.24 or RS-530 with 25-pin D-type, female
 D-type, female
 RS-422/V.36 with 37-pin D-type, female
 V.35 with 34-pin female
 X.21 with 15-pin D-type, female

Note: All synchronous data ports are equipped with 25-pin D-type, female connectors. Adaptor cables for the V.35, V.36 and X.21 interfaces are supplied with the unit.

FIBER OPTIC INTERFACE

Types

See Table 1

Compliance

ITU G.921, G.955 (11/1996)

WAN PROTOCOLS

Type

Frame Relay - RFC 1490
 PPP and MLPPP

ROUTING

Types

STATIC, RIP-1, RIP-2, RIP/SAP, OSPF

ARP Table

Up to 300 MAC addresses

GENERAL

Power

AC: 100 to 240 VAC ($\pm 10\%$), 50 to 60 Hz,
 13 VA max
 DC: -20 to -72 VDC, 7.8W

Physical

Height: 4.4 cm (1.8 in) (1U)
 Width: 21.6 cm (8.5 in)
 Depth: 24.0 cm (9.4 in)
 Weight: 1.1 kg (2.5 lb)

Environment

Temperature: 0°-50°C (32°-122°F)
 Humidity: Up to 90%, non-condensing

Table 1. Fiber Optic Interface Characteristics

Wavelength [nm]	Fiber Type [μm]	Transmitter Type	Power [dBm]	Receiver Sensitivity [dBm]	Typical Max. Range	
					[km]	[mi]
850	62.5/125 multimode	VCSEL	-18	-38	5	3
1310	9/125 single mode	Laser	-12	-39	62	38
1550	9/125 single mode	Laser	-12	-39	100	62

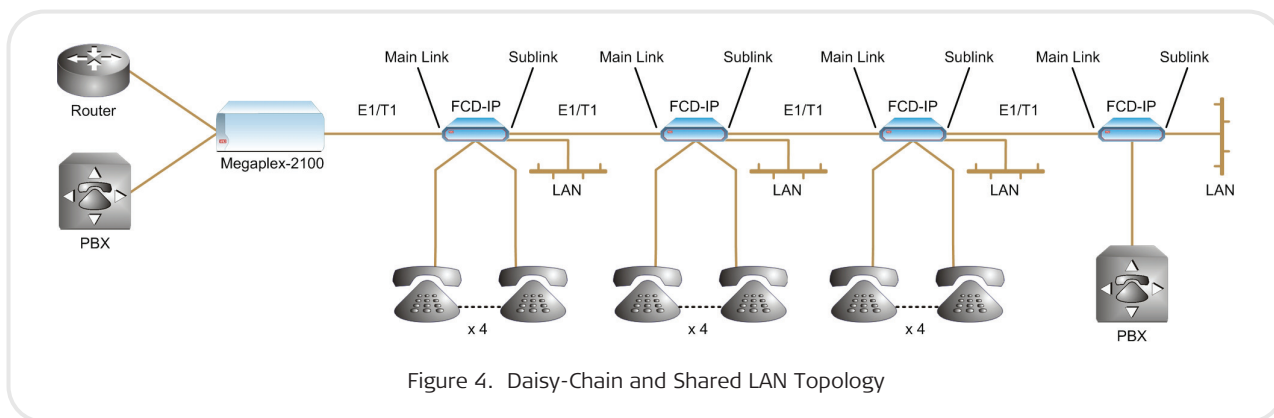

Figure 4. Daisy-Chain and Shared LAN Topology

FCD-IP

E1/T1 or Fractional E1/T1 Access Unit with Integrated Router

Ordering

FCD-IP/~/\$/+/*

E1/T1 or fractional E1/T1 access unit with integrated router

Legend

~ Optional DC power supply:
DC -20 to -72 VDC

Note: The default power supply is AC.

\$ Primary WAN interface with optional second data port:

E1/# E1 or fractional E1 (RJ-45 only)

T1/# T1 or fractional T1

E1/?/!/# E1 or fractional E1 with built-in fiber optic modem

T1/?/!/# T1 or fractional T1 with built-in fiber optic modem

Note: The T1 line cannot be used for a ring application.

Optional second WAN interface:

V24T V.24/RS-232 (DTE)

V35T V.35 (DTE)

530T RS-530 (DTE)

V36T V.36/RS-422/RS-449 (DTE)

X21T X.21 (DTE)

or

Serial port interface:

V24C V.24/RS-232 (DCE)

V35C V.35 (DCE)

530C RS-530 (DCE)

V36C V.36/RS-422/RS-449 (DCE)

X21C X.21 (DCE)

Note: All synchronous data ports are equipped with 25-pin D-type, female connectors. Adapter cables for the V.35, V.36, and X.21 interfaces are supplied with the unit.

? Fiber optic connector:

ST ST connector

FC FC/PC connector

SC SC connector

! Wavelength and type:

85 850 nm, multimode, VCSEL

13L 1310 nm, single mode laser diode

15L 1550 nm, single mode laser diode

+ LAN interface:

U 10/100BaseT (UTP)

2U 2 × 10BaseT (UTP)

4U 4 × 10/100BaseT (UTP) built-in switch

* Optional sub-E1/T1, analog voice or ISDN backup interfaces:

S sub-E1/T1 port (RJ-45 only)

2S 2 sub-E1/T1 ports (RJ-45 only)

3S 3 sub-E1/T1 ports (RJ-45 only)

FXS 4 FXS voice channels

FXO 4 FXO voice channels

E&M 4 E&M voice channels

IBE ISDN "S" interface

IBU ISDN "U" interface

FXS/S 4 FXS voice channels and one sub-E1/T1 port

FXO/S 4 FXO voice channels and one sub-E1/T1 port

E&M/S 4 E&M voice channels and one sub-E1/T1 port

IBE/S ISDN "S" interface and one sub-E1/T1 port

IBU/S ISDN "U" interface and one sub-E1/T1 port

Notes: The second WAN option is not available when configuring E1/T1 with an ISDN backup.

The dual LAN configuration is not available when configuring E1/T1 with an ISDN backup.

The line cannot be fiber for options 3S, FXS/S, FXO/S, E&M/S, IBE/S, or IBU/S.

3S (3 sub-E1/T1 ports) cannot be installed with an additional FXO, FXS, E&M, IBE, or IBU.

SUPPLIED ACCESSORIES

Power cord

DC power connection kit (when DC power supply is ordered)

CBL-RJ45/D9/F/6FT

Control port cable

When V.35, V.36, or X.21 interfaces are ordered, adaptor cables are supplied with the unit.

OPTIONAL ACCESSORIES

CBL-RJ45/2BNC/E1

Interface cable for converting a balanced E1 RJ-45 connector into a pair of BNC unbalanced coaxial connectors

RM-17

Hardware kit for mounting one or two FCD-IP units into a 19-inch rack

International Headquarters
24 Raoul Wallenberg Street
Tel Aviv 69719, Israel
Tel. 972-3-6458181
Fax 972-3-6498250, 6474436
E-mail market@rad.com



12 avenue des prés
78059 St Quentin en Yvelines
Tel: 33 (0)1 77 55 03 00
Fax: 33 (0)1 30 44 11 95
E-mail: sales@cbnetworks.fr



data communications
The Access Company