

Optimux-1551

E1/T1 STM-1/OC-3 Terminal Multiplexer



Any Traffic over Fiber



- STM-1 or OC-3 terminal multiplexer providing access to SDH and SONET networks
- Multiplexes 21/42/63 E1 or 28/56/84 T1 data channels over a single link, providing a cost-effective and reliable solution
- 1+1 unidirectional SDH/SONET automatic protection for uplink, as well as 1+1 protection on E1/T1 tributaries
- Plug-and-play operability

Optimux-1551 is an STM-1/OC-3 multiplexer that combines high capacity, operational simplicity, and cost benefits. Up to 21/42/63 E1 or 28/56/84 T1 tributary channels are mapped into a single channelized STM-1/OC-3 uplink,

for extending the local loop up to 80 km (50 miles), while creating a transmission layer fully compatible with regional and national SDH/SONET networks.



Optimux-1551

E1/T1 STM-1/OC-3 Terminal Multiplexer

E1/T1 over SDH/SONET applications are supported via preset software configurations for operation in multinational environments.

All modules, including fans and power supplies, are hot-swappable, making Optimux-1551 fully compatible with carrier class requirements.

Uplink 1+1 unidirectional redundancy is supported in compliance with the G.841 and GR-253-CORE standards. Tributary channel 1+1 protection is provided through an optional redundant module.

Optimux-1551 is available with a choice of either standard coaxial or fiber optic short/long-haul aggregate uplink interfaces.

Three dual-purpose multiplexer cards each with 21E1/28T1, 42E1/56T1 and 63E1/84T1 tributary channels support transparent data transfer in compliance with the G.703 recommendation. The TDM traffic is mapped into SDH or SONET containers, while retaining full use of the 155 Mbps capacity.

An optional station clock card can be installed on the OP-2128/OP-4256/OP-6384 card. When both the station clock and an external clock are used, the unit's transmit clock for transmission over the STS-3/OC-3/STM-1 uplink is locked to the station clock input source. The input source can be either one of the E1/DS1 tributaries or a dedicated external E1/DS1 input.

Compact size and low power consumption of Optimux-1551 allow easy installation at customer premises or in telecommunication buildings.

Setup, control, status monitoring, and diagnostics information can be performed using one of the following methods:

- ASCII terminal connected to the DB-9 control port
- Telnet host via the dedicated Ethernet port
- Network management station (NMS) running RADview-EMS, RAD's client-server CORBA-based SNMP network management application. NMS is connected via the dedicated Ethernet port
- Web Server (ConfiguRAD), RAD's Web-based remote access terminal application, via the dedicated Ethernet port
- TFTP for software update and remote configuration, via the dedicated Ethernet port.

The unit provides high-quality performance monitoring of the traffic path, from the SDH/SONET network to the customer premises, thereby assuring high availability.

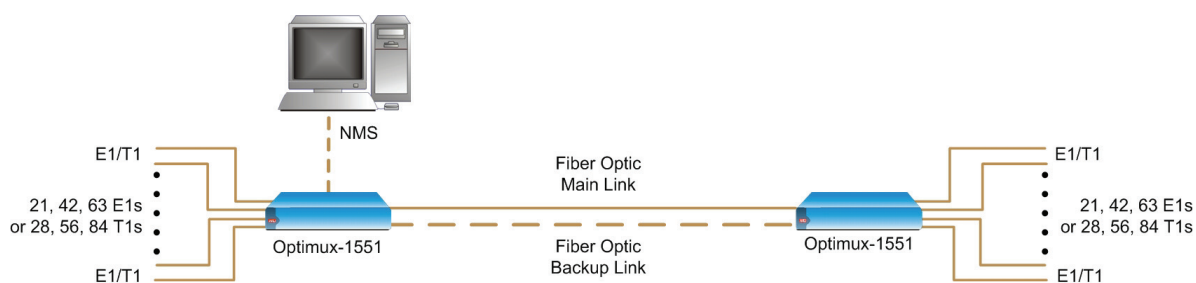

Figure 1. Point-to-Point Application

Specifications

STM-1/OC-3 UPLINK (NETWORK)

Compliance

Bellcore GR-253-CORE,
Bellcore GR-499-CORE, ITU-T G.703,
G.707, G.783, G.841, G.957, RFC 3592

Redundancy

1+1

Line Rate

155.52 Mbps \pm 20 ppm

ELECTRICAL (COAX) INTERFACE

Line Attenuation

Typically 12.7 dB at 78 MHz using
RG-59-B/U cable

Impedance

75 Ω

Connectors

BNC

Line Code

CMI

FIBER OPTIC INTERFACE

Line Code

NRZ scrambled

Specifications and Ranges

See *Table 1*

E1 TRIBUTARY CHANNELS

Standards

ITU-T Rec. G.703, G.823, RFC 3895

Data Rate

2.048 Mbps

Line Code

HDB3 or AMI

Impedance

120 Ω balanced
75 Ω unbalanced

Range

According to ITU-T rec. G.703

Jitter

According to ITU-T rec. G.823

Connectors

Six 64-pin unshielded Telco

T1 TRIBUTARY CHANNELS

Standards

ITU-T Rec. G.703, G.824, RFC 3895

Data Rate

1.544 Mbps

Line Code

B8ZS or AMI

Impedance

100 Ω balanced

Range

According to ITU-T rec. G.703

Jitter

According to ITU-T rec. G.824

Connectors

Six 64-pin unshielded Telco

SUPERVISORY AND MANAGEMENT PORTS

Control Port

Interface: V.24/RS-232

Connector: DB-9, female

Format: asynchronous

Baud rate: 9,6 kbps, 19,2 kbps,
38,4 kbps, 57,6 kbps, 115,2 kbps

Ethernet Port

Interface: 10/100BaseT

Connector: RJ-45 shielded

Mode of operation: autonegotiation,
full/half duplex

ALARM RELAY

Rating

60 VDC max or 30 VAC max, at 0.5A max

Input Alarm

10 VDC min, 48 VDC max, at 0.5A max

Connector

Dry contact, DB-9 female

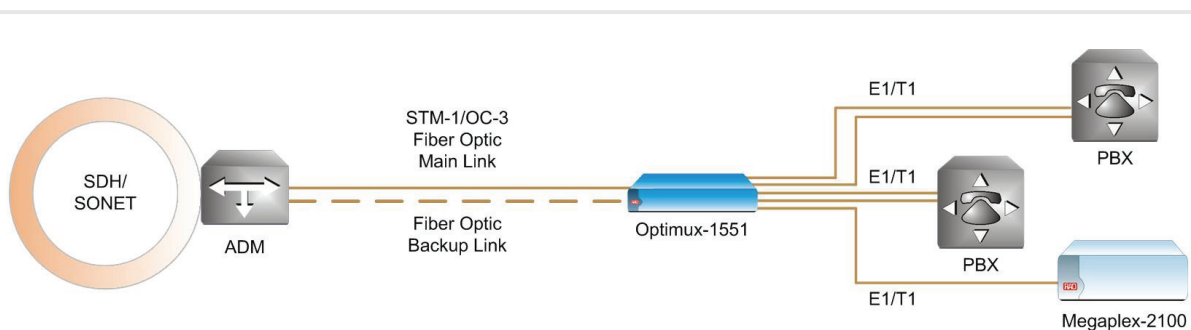

Figure 2. Extending SDH/SONET Service to Remote Customers

Optimux-1551

E1/T1 STM-1/OC-3 Terminal Multiplexer

INDICATORS

Power A, B

Green: Power is OK

Red: Power fault

Off: No power

System

TST (yellow):

- On: Unit is in test mode
- Flashing: Downloading soft

FLT (red): OP-6384/OP-2128/OP-4256 card is in fault condition

ON A/B (green):

- On: Active OP-6384/OP-2128/OP-4256 card
- Flashing: During auto-baud detect process.

Alarm

MAJ (red):

- On: Major Alarm
- Flashing: Major Alarm + ACO button pressed

MIN (yellow):

- On: Minor Alarm
- Flashing: Minor Alarm + ACO button pressed

Uplink

SYNC A/B LOSS (red): Electrical/optical signal not present or out-of-frame detected on uplink (A/B)

AIS A/B (yellow): AIS signal detected on uplink A/B

SIG (green): Signal detected on the respective uplink card

Channels

SYNC LOSS/AIS (red/yellow):

- Red: Loss of signal detected on the respective non masked channel.
- Yellow: AIS signal detected on the respective non masked channel
- Flashing: The channel is masked and the LED status for the masked channels' parameter is set to Blink by the user.
- Off: The channel is masked and the LED status for the masked channels' parameter is set to Off by the user or when the channel is not masked and no Loss of Signal or AIS is detected on the respective channel.

DIAGNOSTICS

Uplink and Tributary Links

Local Loopback

Remote Loopback

GENERAL

Power

AC: 100 - 240 VAC ($\pm 10\%$), 50 to 60 Hz

DC: -48 VDC (-40 to -72 VDC)

Power Consumption

AC: 160 VA max, 1.6A max

DC: 70W max, 2A max

Physical

Height: 8.9 cm (3.5 in)

Width: 43.5 cm (17.1 in)

Depth: 31.5 cm (12.4 in)

Weight: 8.0 kg (11.0 lb) max.

Environment

Temperature: 0°-55°C (32°-131°F)

Humidity: Up to 90%, non-condensing

Table 1. Uplink Interface Options

Module Name (Ordering Option)	Wavelength	Fiber Type	Transmitter Type	Power Coupled into Fiber	Receiver Sensitivity	Typical Max. Range		Connector Type
	[nm]	[μ m]		[dBm]	[dBm]	[km]	[miles]	
OP-M/CX/155	-	Copper cable	-	-	-	135m	443 ft	Coax interface See <i>Note 1</i>
OP-M/SC/85L OP-M/FC/85L OP-M/ST/85L	850	62.5/125 multimode	Laser (VCSEL)	-14 to -20	-26	2.0	1.2	SC, FC, ST
OP-M/SC/13M OP-M/ST/13M	1310	62.5/125 multimode	LED	-14 to -20	-31	2.0	1.2	SC, ST
OP-M/SC/13L OP-M/FC/13L OP-M/ST/13L	1310	9/125 single mode	Laser	-8 to -15	-31	20	12.4	SC, FC, ST
OP-M/SC/15L OP-M/FC/15L OP-M/ST/15L	1550	9/125 single mode	Laser	-8 to -15	-31	20	12.4	SC, FC, ST
OP-M/SC/13LH OP-M/FC/13LH OP-M/ST/13LH	1310	9/125 single mode	Laser (long haul)	0 to -5	-34	40	24.8	SC, FC, ST
OP-M/SC/15LH OP-M/FC/15LH OP-M/ST/15LH	1550	9/125 single mode	Laser (long haul)	0 to -5	-34	80	49.7	SC, FC, ST
OP-M/SC/SF1	Tx: 1310 Rx: 1550	9/125 single mode (single fiber)	Laser WDM	-8 to -15	-29	20	12.4	SC
OP-M/SC/SF2	Tx: 1550 Rx: 1310	9/125 single mode (single fiber)	Laser WDM	-8 to -15	-29	20	12.4	SC
OP-M/SC/SF3	Tx/Rx: 1310	9/125 single mode (single fiber)	Laser (SF3)	-8 to -15	-27	20	12.4	SC/APC

Notes: 1. For copper cables (coax interface), a range of 135m is attainable when using RG-59 B/U (at 78 MHz, in accordance with the square root frequency law).

2. The ranges specified above were calculated according to the following typical attenuation rates (with a 3 dB margin):

- 3.5 dB/km for 850 nm multimode
- 0.4 dB/km for 1310 nm single mode
- 0.25 dB/km for 1550 nm single mode

Optimux-1551

E1/T1 STM-1/OC-3 Terminal Multiplexer

Ordering

OP-1551/*/\$/#/!/?!/+/^

Note: Uplink modules, tributary modules, interface adaptors and cables are all ordered separately.

OP-1551-M/*/\$

Additional tributary module

OP-M/?/+

Uplink interface module only (see *Table 1*)

Legend

* Tributary interface module:

2128	Module with 21×E1 or 28×T1 links
4256	Module with 42×E1 or 56×T1 links
6384	Module with 63×E1 or 84×T1 links
2X2128	Two 2128 modules
2X4256	Two 4256 modules
2X6384	Two 6384 modules

\$ Station clock:

STC Optional station clock

Note: For tributary module redundancy, order two modules. Each tributary module can be set for operation with either E1 or T1 channels.

Power supply:

AC 100 to 240 VAC

48 -48 VDC

AD 100 to 240 VAC power supply plus redundant -48 VDC power supply

! Redundant power supply:

R Redundant power supply of same type

? Uplink connector:

ST ST fiber

SC SC fiber

FC FC fiber

Note: For single fiber connection, only SC type connectors are available. For 1310 nm multimode LED option, only SC and ST type connectors are available.

+ Optical wavelength and transmitter type (not relevant with CX option):

CX Electrical interface with coaxial BNC connectors

13 1310 nm, multimode LED

13L 1310 nm, single mode, laser diode

15L 1550 nm, single mode, laser diode

13LH 1310 nm, single mode, long-haul laser diode

15LH 1550 nm, single mode, long-haul laser diode

85L 850 nm, multimode VCSEL

SF1 Transmit 1310 nm, receive 1550 nm

SF2 Transmit 1550 nm, receive 1310 nm

SF3 1310 nm single wavelength laser

Note: For single-fiber applications, a device with the SF-1 connector should always be used opposite the device with the SF-2 connector, and vice versa. The SF-3 connector can be used on both sides of the link.

^ Redundant STM-1 uplink (default = single uplink):

D Redundant uplink for unidirectional 1+1 protection

SUPPLIED ACCESSORIES

AC power cord

(when AC power supply is ordered)

DC adapter plug

(when DC power supply is ordered)

OP-1551-FT

Fan tray module (one included)

RM-36

Hardware for mounting a single Optimux-1551 in a 19-inch rack

OPTIONAL ACCESSORIES

OP-1551-PS/AC

100 to 240 VAC Power Supply

OP-1551-PS/48

-48 VDC Power Supply

OP-A/ADAPTOR/%

Legend

% Patch panel interface:

21BNC/1551 Patch panel with 21 BNC unbalanced E1 interfaces

28RJ Patch panel with 28 RJ-45 balanced E1/T1 interfaces

Note: Two CBL-TELCO-TELCO/2M cables are included with each patch panel.

CBL-TELCO-OPEN/2M

Adapter cable Telco 64-pin, open-ended, 2m (6.5 ft)

CBL-TELCO-RJ45/2M

Adapter cable Telco 64-pin to 14 RJ-45 connectors, 2m (6.5 ft).

CBL-TELCO-RJ45-CROSS/2M

Adapter cable Telco 64-pin to 14 RJ-45 connectors with cross-connections, 2m (6.5 ft)

CBL-TELCO-TELCO/2M

Adapter cable for balanced interface, Telco 64-pin to Telco 64-pin, 2m (6.5 ft)

Note: Five (E1) or six (T1) Telco-Telco cables are required to support all the tributary channels. Two CBL-TELCO-TELCO/2M cables are included with each OP-A/ADAPTOR patch panel

Blank Panels

Note: To ensure good ventilation during operation, all empty slots must be covered by blank panels.

OP-1551-PS-BP

Power supply blank panel

OP-M-BP

Main module blank panel

OP-1551-M-BP







Tributary interface module blank panel

Optimux-1551

E1/T1 STM-1/OC-3 Terminal Multiplexer

168-100-12/09 Specifications are subject to change without prior notice. © 1997-2009 RAD Data Communications Ltd. The RAD name, logo, logo type, and the terms EtherAccess, TDMoIP and TDMoIP Driven, and the product names Optimux and Irmux are registered trademarks of RAD Data Communications Ltd. All other trademarks are the property of their respective holders.

Table 2. Optimux Comparison Table

Feature	Optimux-108L 	Optimux-108/106 	Optimux-34/25 	Optimux-45/45L 	Optimux-1551 	Optimux-1553 
Uplink	Fiber Optic	Fiber Optic	E3, Fiber Optic	T3, Fiber Optic	Copper, STM-1/OC-3	Copper, STM-1/OC-3
Bandwidth (Mbps)	108	108/81	34/25	45	155	155
Number of trunks	4 E1	4 E1/4 T1	16 E1/16T1	21 E1/28 T1	21/42/63 E1 28/56/84 T1	3 E3/3 T3
Ethernet support	✓	✓	✓	-	-	-
Special features	Reduced Power Consumption Cost-Effective	Redundant, hot-swappable uplinks	SFP-based uplinks	Ring support (Optimux-45)	Full redundancy	Full redundancy
Card version for LRS-102		✓	✓			

International Headquarters
 24 Raoul Wallenberg Street
 Tel Aviv 69719, Israel
 Tel. 972-3-6458181
 Fax 972-3-6498250, 6474436
 E-mail market@rad.com



12 avenue des prés
 78059 St Quentin en Yvelines
 Tel: 33 (0)1 77 55 03 00
 Fax: 33 (0)1 30 44 11 95
 E-mail: sales@cbnetworks.fr



data communications
 The Access Company